



Data sheet

Contec.greenlight

Version february 2025



## Table of contents

Technical data Contec.greenlight.....	3 - 8
Data sheet Contec.greenlight profile rail universal.....	9 - 12
Data sheet Contec.greenlight determination of permissible snow load/wind load .....	13
Data sheet Contec.greenlight recommendation lightning protection .....	14 - 27
Factsheet Contec.greenlight .....	18 - 19

## Technical data

Contec.greenlight base plate	1980 mm x 980 mm x 60 mm	
Weight per unit	12 kg, weight without ballast, without PV module	
Material	Recycled HDPE, magnelis, aluminium, stainless steel and galvanized steel	
Water storage volume	39.5 liters, unfilled	
Filling volume base plate	70 liters (substrate backfilled flush)	
Compressive strength	Compressive strength unfilled:	> 25 kN/m <sup>2</sup>
	Compressive strength backfilled (flush backfilled):	> 70 kN/m <sup>2</sup>
Water drainage capacity	i = 0.01 (= 1 % gradient)	0.4 l/(m*s)
	i = 0.02 (= 2 % gradient)	0.6 l/(m*s)
	i = 0.05 (= 5 % gradient)	1.0 l/(m*s)
Standard module inclination	10°, 15°, 20° standard (optional)	
Roof connection	No structural roof connection necessary	
Ballasting	Surcharge load and distance base plate must be compulsorily calculated by Contec AG according to the wind zone plan.	
Roof pitch	Inclination up to 5° approved. From 5°: Release only with technical clarification by Contec AG.	
Unit consists of	1 x Contec.greenlight base plate 1 x Knickfix 2.0 m to 3.4 m profile rail Small material (screws, profile connectors, clamps)	
Warranty	10 year system warranty on Contec.greenlight substructure ex works, valid from date of delivery.	

# Technical data

## Contec.greenlight portrait east-west

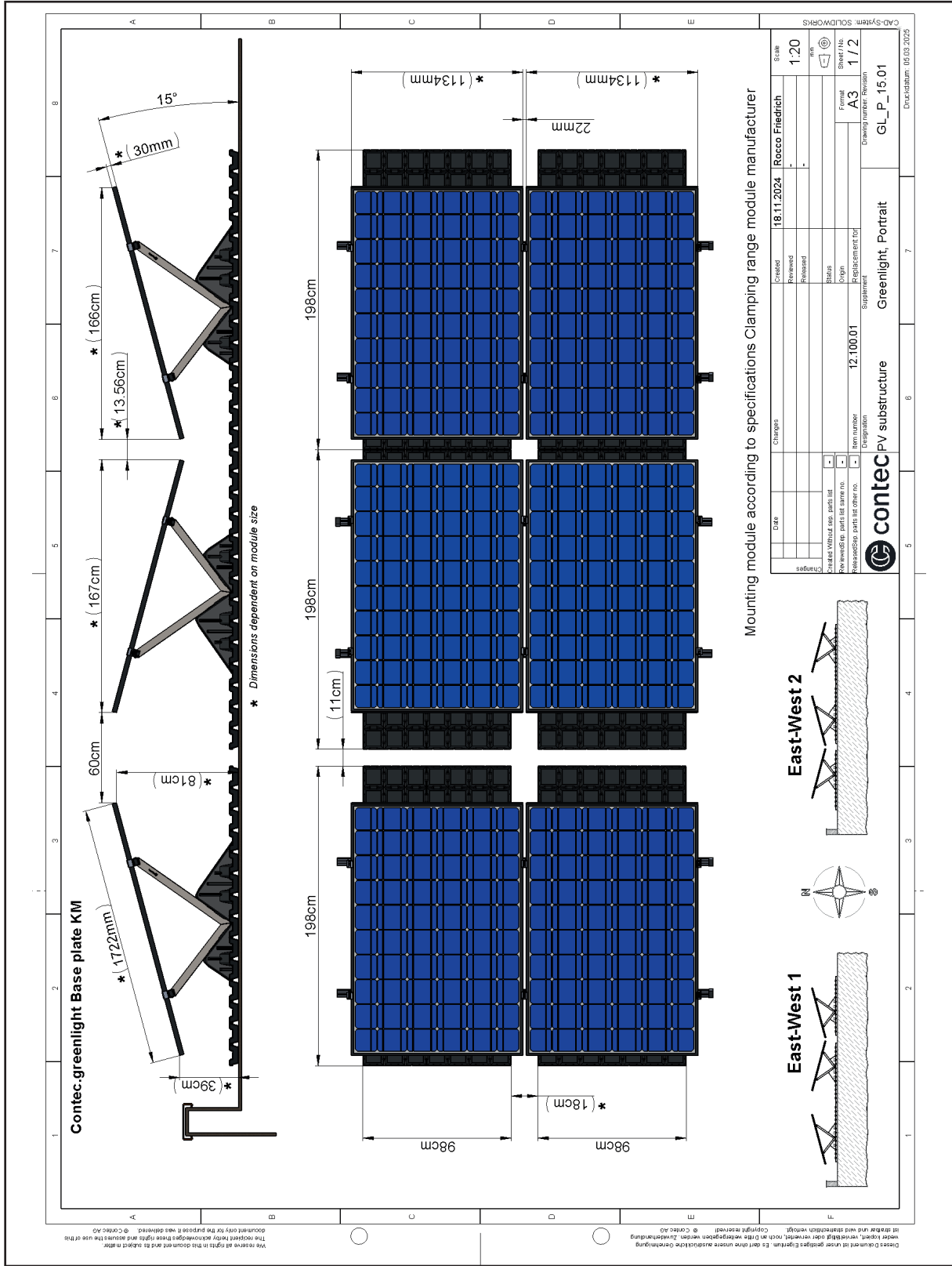

# Technical data

## Contec.greenlight portrait south

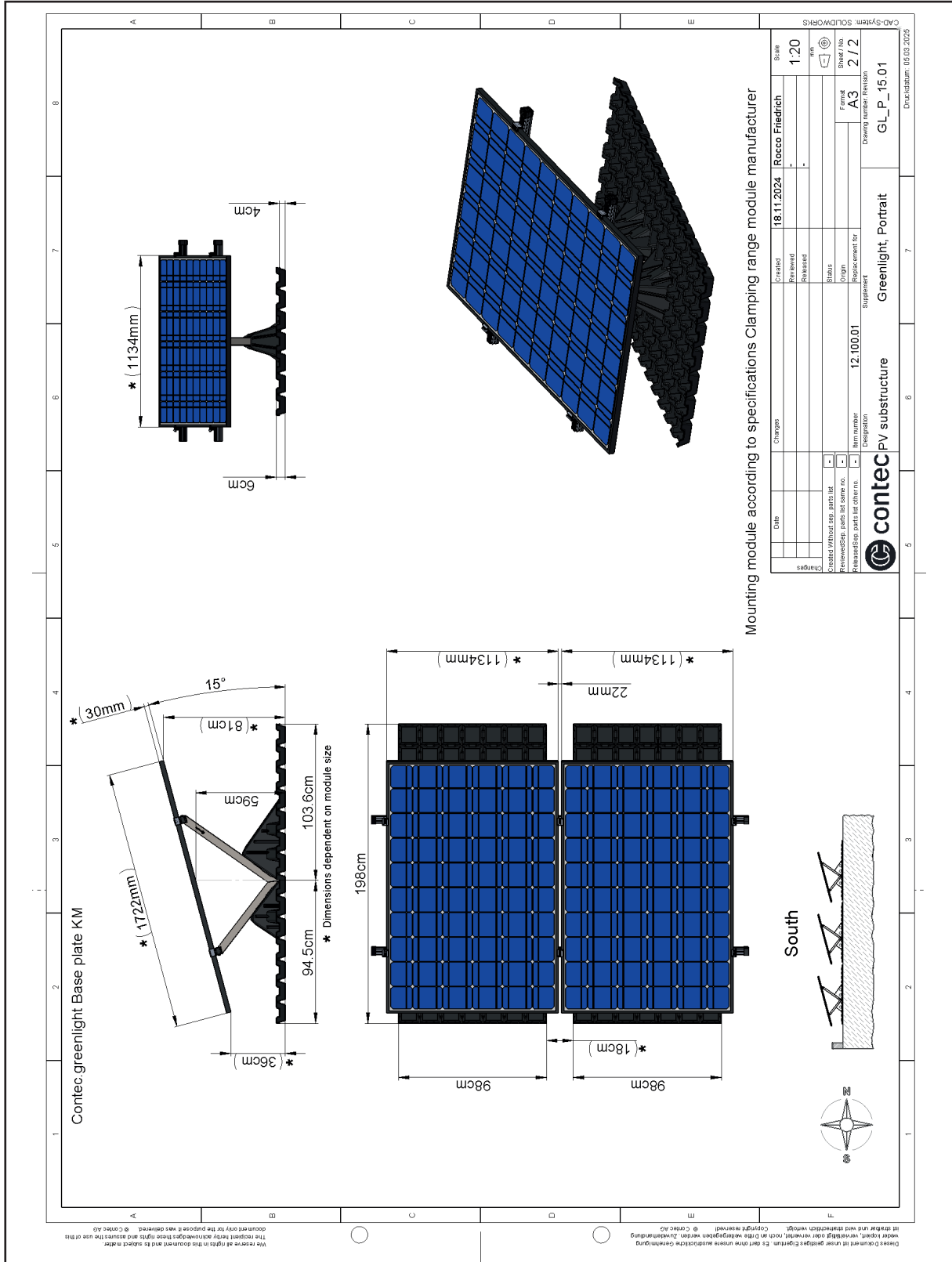

# Technical data

## Contec.greenlight landscape east-west

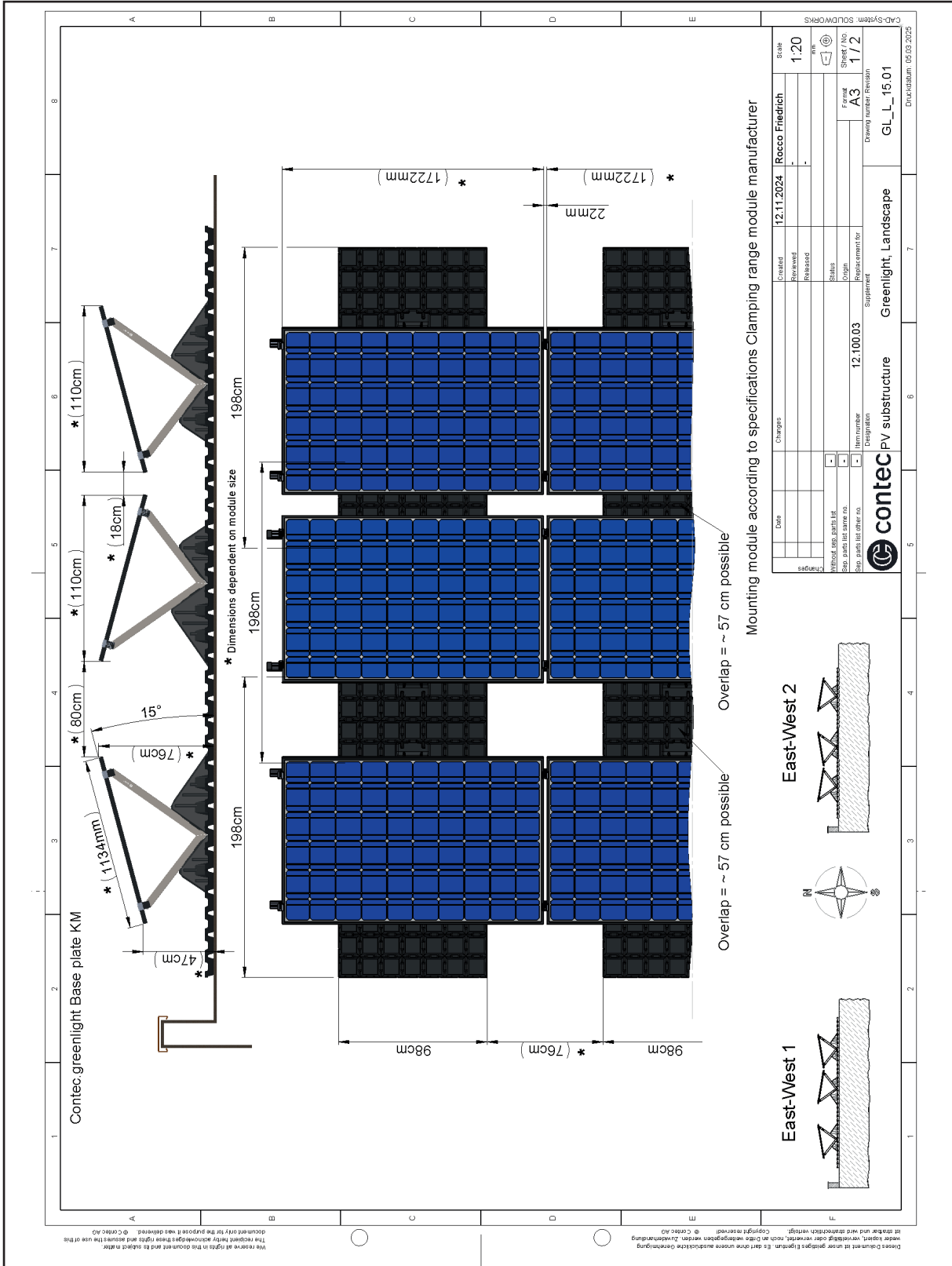

# Technical data

## Contec.greenlight landscape south

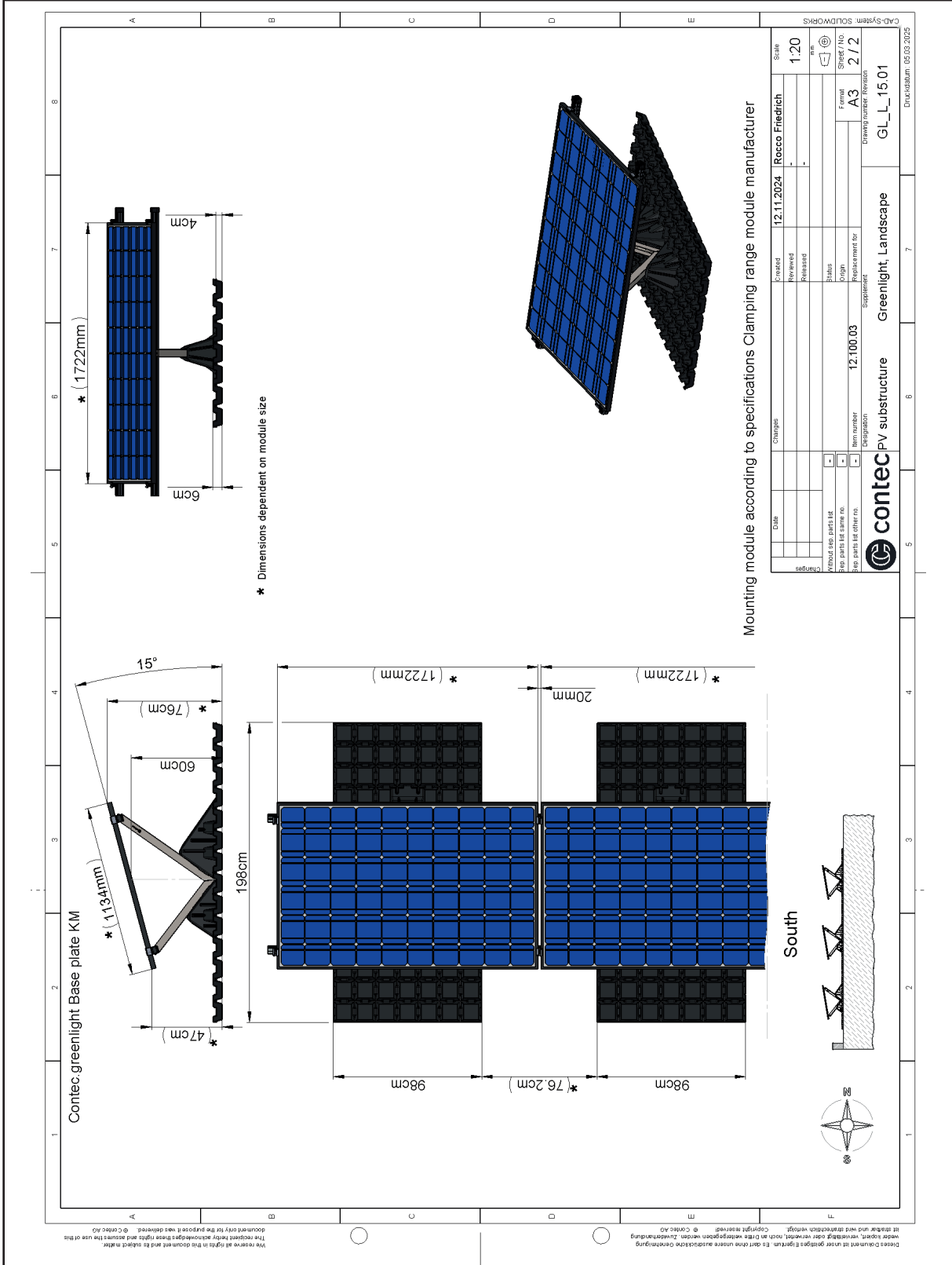

## Technical data

### Contec.greenlight base plate

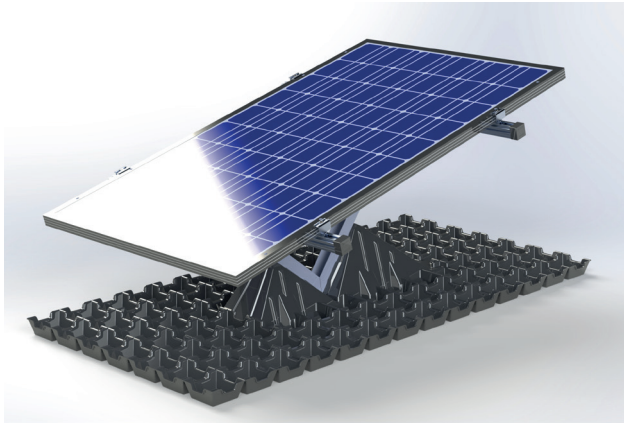

Panel dimensions: 1'980 x 980 x 60 mm

Water storage volume: 39.5 liters unfilled

#### Contec.greenlight, portrait 10°, butterfly shape

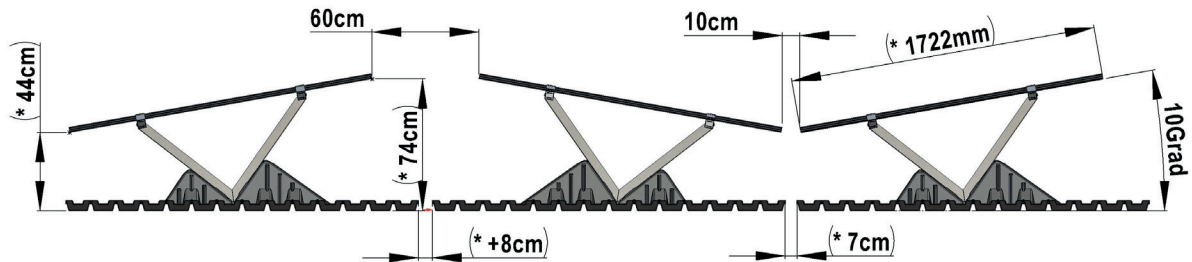

\*Mass depends on module

#### Contec.greenlight, portrait 10°, roof shape/saddle shape

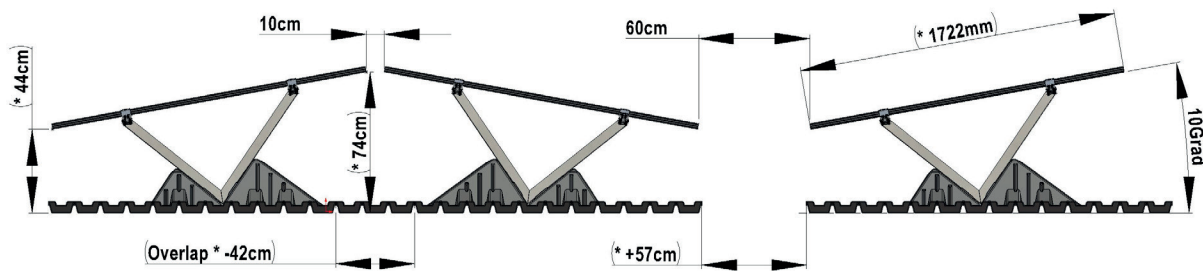

\*Mass depends on module

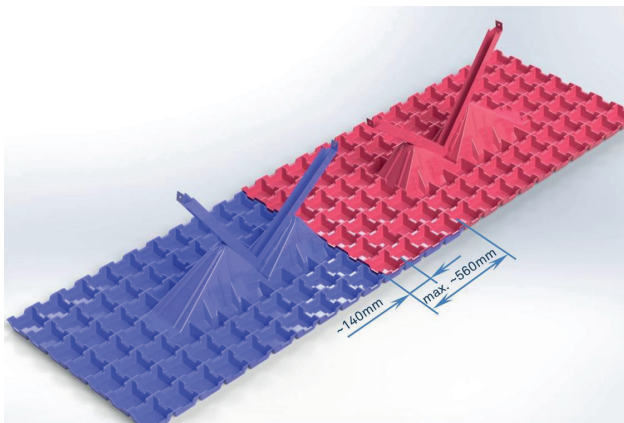

#### Nesting Contec greenlight base plate

Can be nested/overlapped lengthwise and crosswise up to the hump.

Grid dimension/step dimension = 140 mm



## Data sheet

### Contec.greenlight profile rail universal

Profile rail art. no: 12.205.21 / Material: EN AW-6063 T66 / AlMgSi0,5

EN AW-6063 is traditionally one of the most widely used alloys in the 6000 series. It offers high strength, good corrosion properties and can be decoratively anodized.

EN AW-6063 is also suitable for thermally conductive tasks such as heat exchangers and heat sinks.

Chemical composition according to EN573-3 (weight %, rest Al)

Si	Fe	Cu	Mn	Mg	Cr	Zn	Ti	Comment	Other	
0.20 -0.60	max. 0.35	max. 0.10	max. 0.10	0.45 -0.90	max. 0.10	max. 0.10	max. 0.10		any max. 0.05	Total max. 0.15

Mechanical properties in accordance with EN755-2 %.

State*	Wall thickness e***	Yield strength Rp <sub>02</sub> [MPa]	Tensile strength Rm [MPa]	Stretch		Hardness**
				A [%]	A50mm [%]	
T66	e ≤ 10	200	245	8	6	HB
				8	6	75
	10 < e ≤ 25	180	225	8	6	70

\* Condition according to EN515: T4 solution annealed and cold aged, T5 quenched from the T6- solution annealed and artificially aged, T66- solution annealed and artificially aged - better mechanical properties than T6 due to special control of the process. (properties of T6 and T66 can be achieved by quenching).

\*\* Hardness values are for information only.

\*\*\* For profiles with different wall thicknesses, the lowest specified properties apply.

Physical properties (approximate values, 20°C)

Density [kg/m <sup>3</sup> ]	Melting range [C°]	Electr. conductivity [MS/m]	Thermal conductivity [W/m.K]	Thermal linear expansion 10-6/K	Modulus of elasticity [GPa]
2'700	585 - 650	28 -34	200 - 220	23.4	~70

Weldability\*

Gas: 3 TIG: 2 MIG:2

Typical fillers (EN ISO 18273): AlMg5Cr(A) or AlSi5, and AlMg3 if the product has to be anodized.

product has to be anodized. Due to the heat input during welding the mechanical properties are reduced by about 50%. (Ref. EN1999-1

Machinability\*

Condition T4: 3 condition T5 and T6: 2

Surface treatment\*

Protective anodizing: 1 decoratrives anodizing:1

Corrosion resistance\*

Weathering: 1 sea water: 2

# Data sheet

## Contec.greenlight profile rail universal

Material data sheet - extruded profiles alloy EN AW-6063 [AlMg0.7Si]

Strength values at elevated temperatures

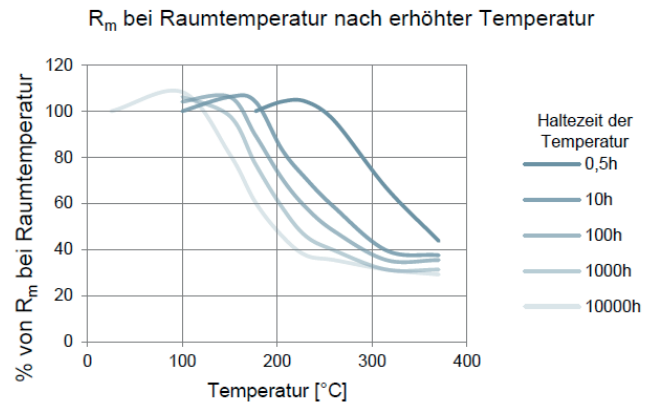
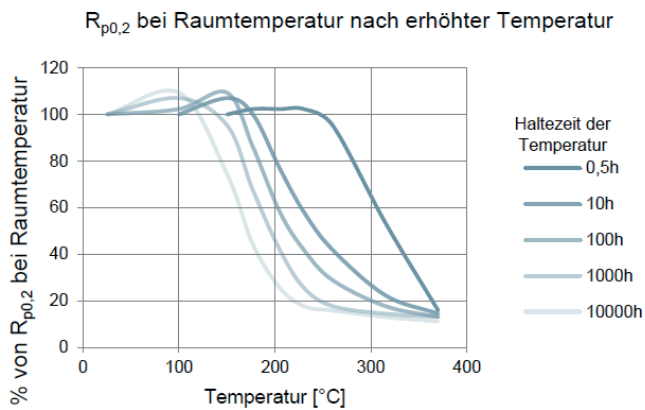
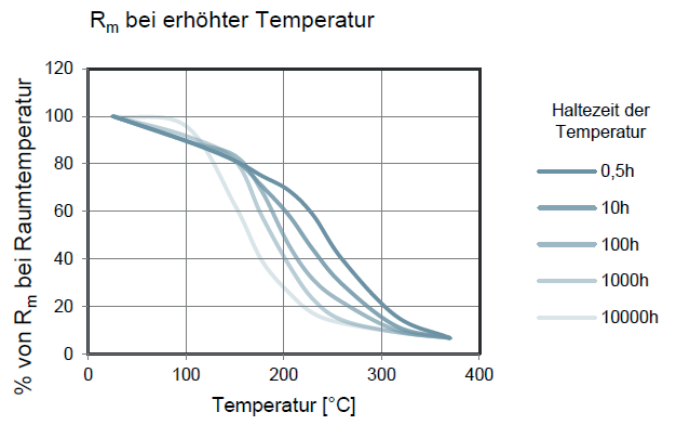
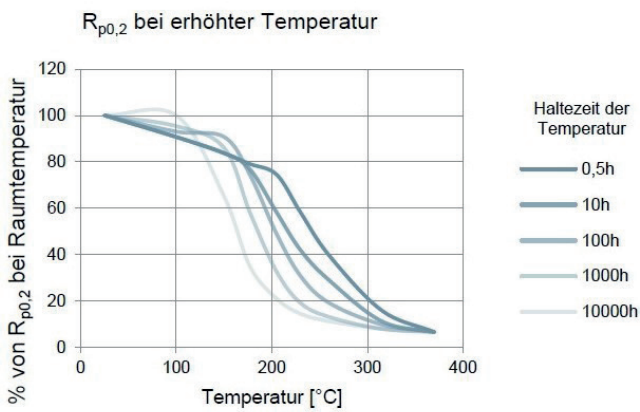

This information is provided as a guide and cannot be guaranteed.

EN AW-6063-T66  
Al-Mg-05Si

Aluminum  
EN-AW -6063-T66  
Area A = 397.5mm<sup>2</sup>  
Electrical conductivity  $\sigma = 36 \mu\Omega \cdot m$   
Conductivity of the profile rail is 34 - 38 MS/my

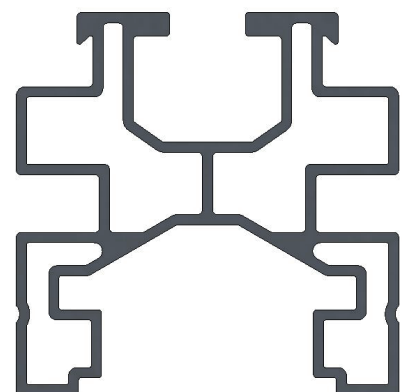

# Data sheet

## Contec.greenlight profile rail universal

Approved module clamps Mounting for universal profile rail

Profile rail part no.: 12.205.21

Material: EN AW-6063 T66 / AlMgSi0.5

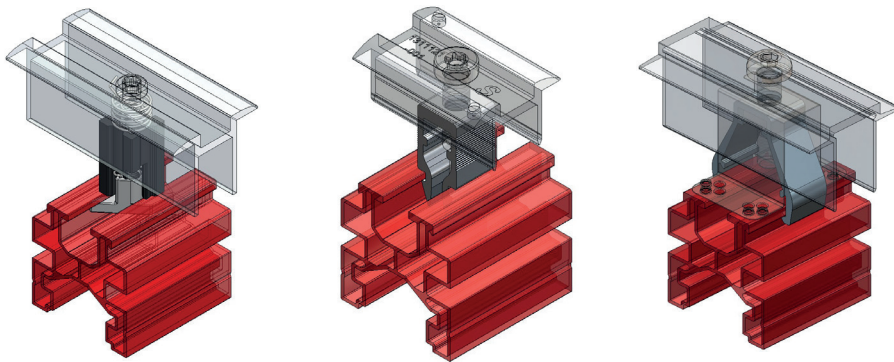

K2

Schletter

S:Flex

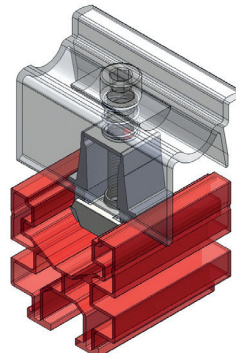
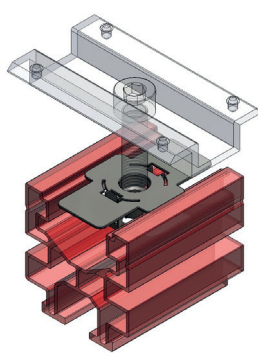
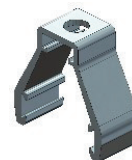
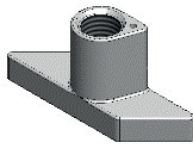

K2

K2

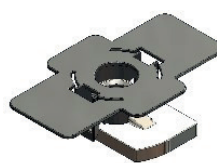
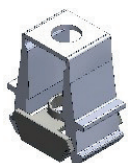

# Data sheet

## Contec.greenlight profile rail universal

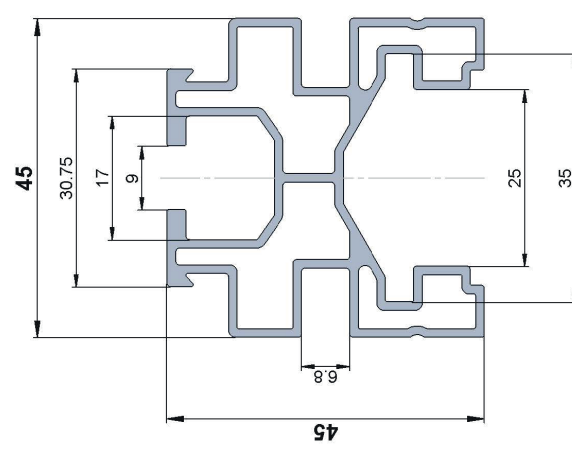

**Length = ~6.1m**

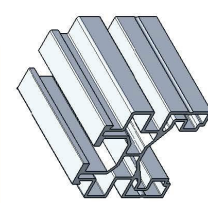

**Material:**  
EN AW- 6063-T66  
Al-Mg-05Si

Ra 1.6-3.2  
Extrusion

Aluminum  
EN-AW -6063-T66  
Area A = 397.5mm<sup>2</sup>  
Electrical conductivity  $\sigma = 36 \mu\Omega \cdot m$   
Conductivity of the profile rail is 34 - 38 MS/m

**Profile rail universal – Contec.greenlight**

R	Datum	Name	Änderung	Erstellt	11.03.2019	M. Wagner	Massstab
01	03.12.19	MW	Nutenmass K2 34mm auf 35mm	Gepflicht	-	-	1.75:1
02	28.08.20	MW	Nutenmass 10.5mm auf 9.0mm	Freigegeben	-	-	
			Stegbreite 2.50mm auf 2.75mm	Auftrags-Nr.	-	-	
			Projekt	Status	-	-	
			Ohne sep. Stückliste	Ursprung	-	-	Fertig
			Sep. Stückliste gleicher Nr. -	Anlieh-Nr.	-	-	A3
			Sep. Stückliste anderer Nr. -	Ersatz für	-	-	1 / 1

Benennung: **Contec profile rail universal**  
Zeichnungs-Nr.: **12.205.21**  
Revision: **1**

Druckdatum: 11.03.2022

Dieses Dokument ist unser geistiges Eigentum. Es darf ohne unsere ausdrückliche Genehmigung weiter kopiert, vervielfältigt oder sonstwie in irgendeiner Weise veröffentlicht werden. Nach dem Abgleich der Daten wird die Verantwortung für die Richtigkeit der Daten übernommen. © Contec AG

ist erstellt und wird stratigraphisch verfolgt. Copyright reserved! © Contec AG

This document is our intellectual property. It may not be copied, reproduced, or otherwise published without our express permission. After data reconciliation, Contec assumes responsibility for the correctness of the data. © Contec AG

This document is our intellectual property. It may not be copied, reproduced, or otherwise published without our express permission. After data reconciliation, Contec assumes responsibility for the correctness of the data. © Contec AG

## Data sheet

### Contec.greenlight

### Determination of permissible snow load /wind load

Portrait

Contec.greenlight

Landscape



Contec.greenlight standard version is approved for a permissible snow load of at least 4.04 kN/m<sup>2</sup> (load coefficient included) in additionally wind-exposed areas. In Switzerland, this corresponds to the snow load at an altitude of sea level of 1050 m.

Contec.greenlight standard version is approved for a permissible wind load of at least 2.40 kN/m<sup>2</sup> (load coefficient included).

→ Use with standard PV modules - with mounting specifications module manufacturer

#### Technical specifications to be met

1 pcs. module to 1 pcs. Contec.greenlight substructure.

Tightening torque module clamps max. = 14 Nm

#### Standard version

Contec.greenlight 10°, 15°, 20° (5°, 25°, 30° optional) portrait

Contec.greenlight 10°, 15°, 20° (5°, 25°, 30° optional) landscape

For project sites with higher loads or PV modules with deviation from standard dimensions, an adaptation of the Knickfix for compliance with the clamping ranges or a reinforced version of the Knickfix for higher loads is possible.

In addition, there is the possibility with a different arrangement of the PV modules to Contec.greenlight substructure in a PV module to reduce the wind forces. This recommendation/specification is made by Contec AG.

## Data sheet

## Contec.greenlight recommendation lightning protection

Profile connector inside

Thermal separation / profile rail interruption

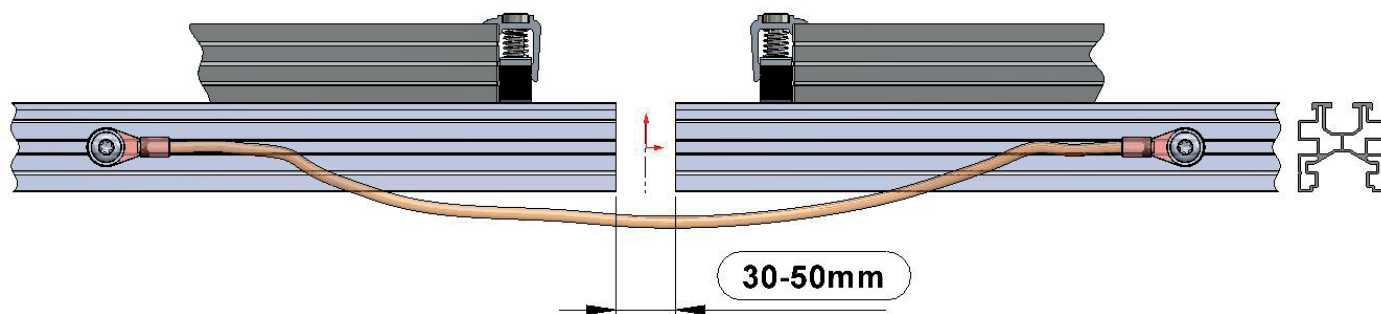
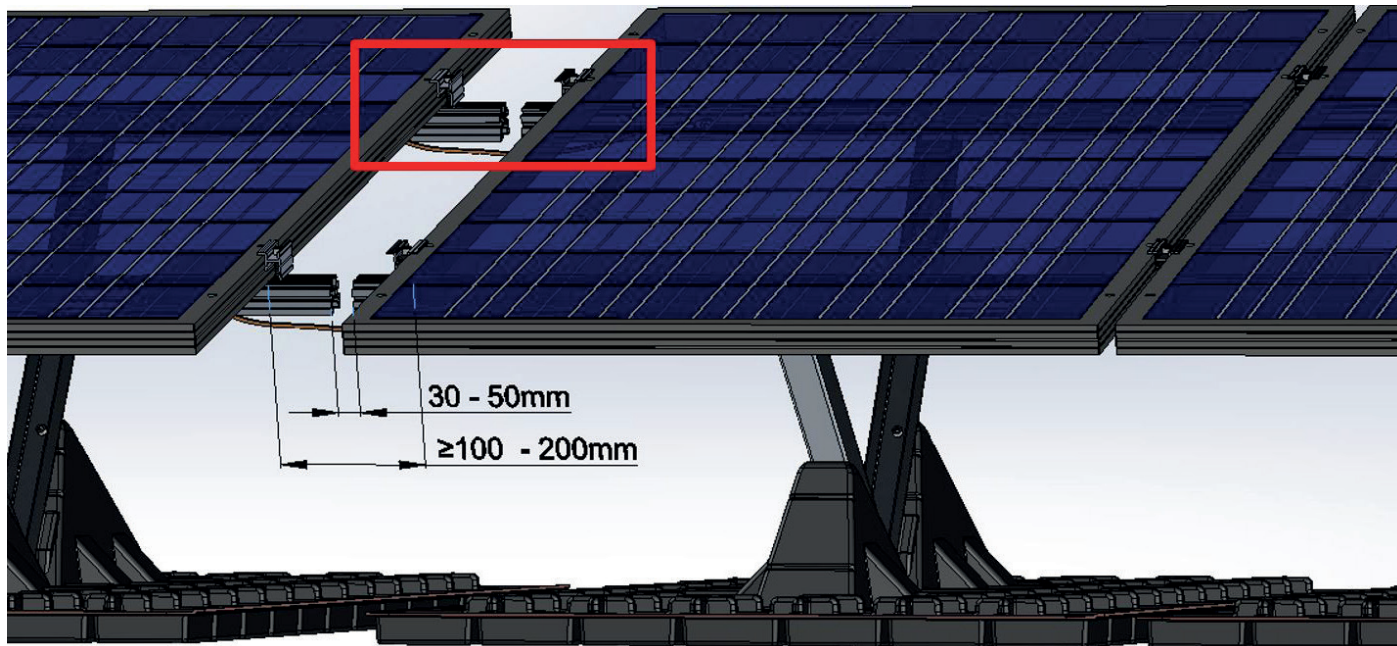

Important: lightning protection must be guaranteed. A lightning current-capable strap loop must be fitted.

Mounting instructions: Thermal break / profile rail interruption

- For continuous profile lengths over 24 m, a thermal break must be integrated.
- A gap of 3 - 5 cm must be left between the two profile rails. The thermal break must be positioned so that it lies between two modules. These are each fastened with an end clamp.

## Data sheet

# Contec.greenlight recommendation lightning protection

Suggestion/examples Installation of lightning protection - Laying the lightning protection via the Knickfix

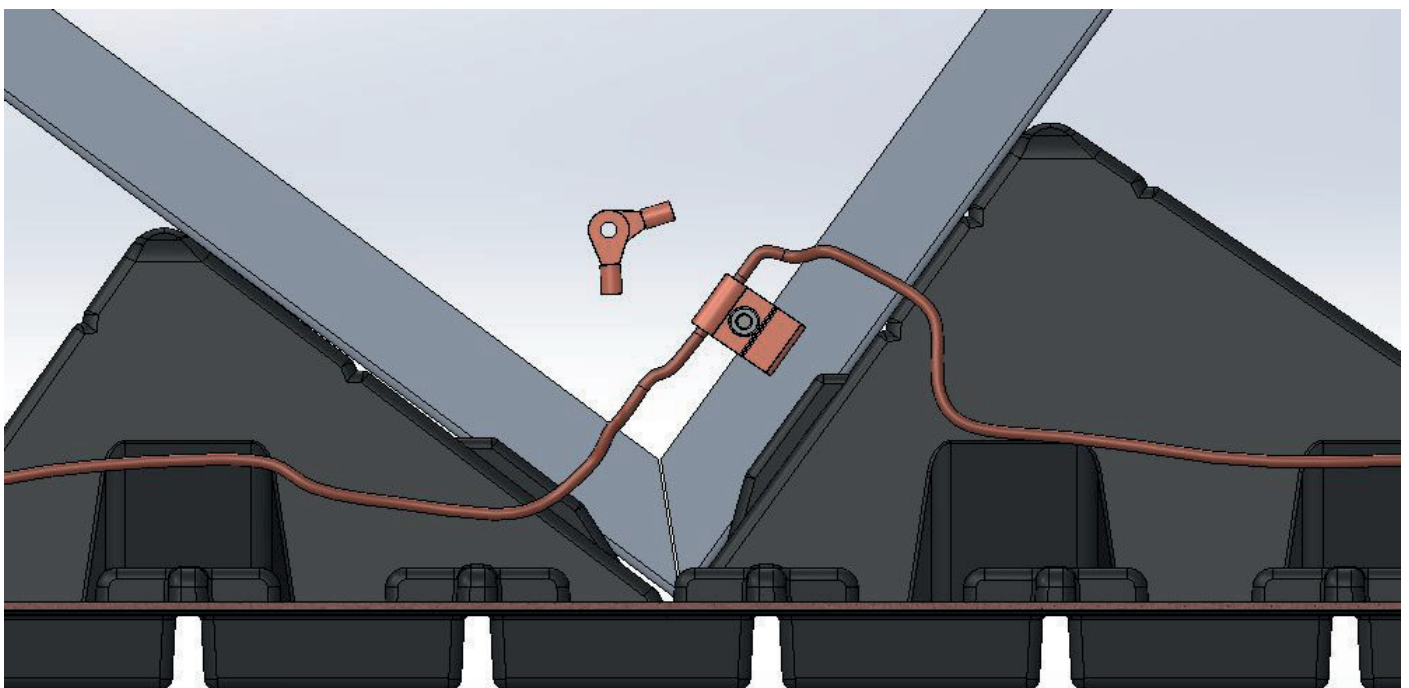
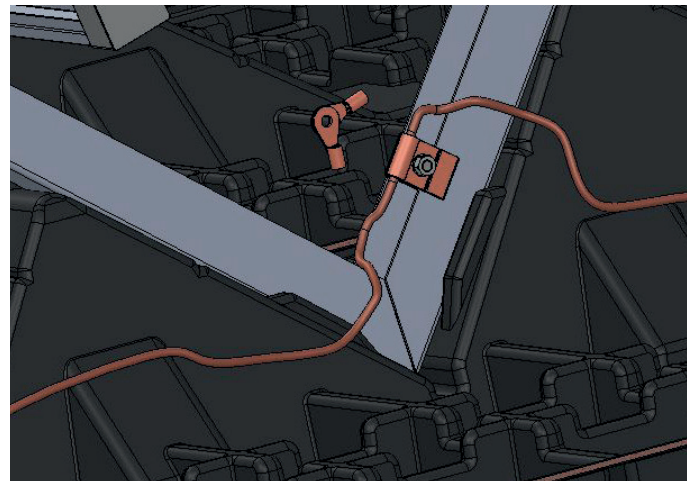
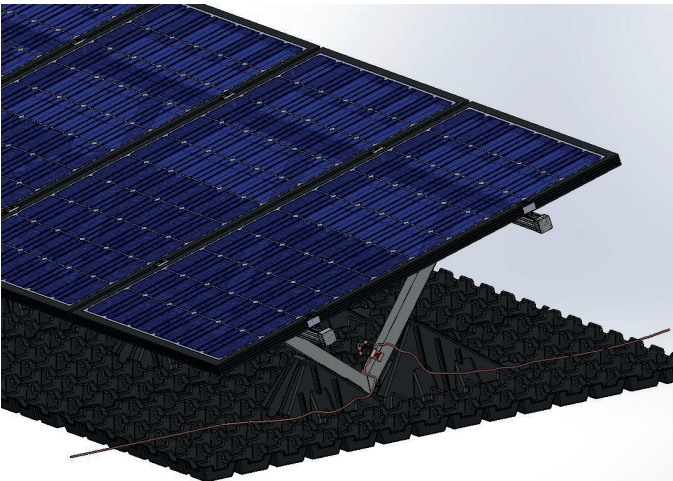

### Lightning protection

Compliance with the regulations and any integration into existing lightning protection systems must be clarified with the local lightning protection officer. The responsibility lies with the creator of the installation.

## Data sheet

# Contec.greenlight recommendation lightning protection

### Relocation of the catch distance/mesh size

Depending on the lightning protection class of the building, different mesh sizes/interception distances apply. If the total length  $L$  is greater than 20 m, an expansion piece must also be inserted to bridge the temperature-related change in length.

Lightning protection class	Catch distances / mesh size [ m ]
I	5 x 5 m
II	10 x 10 m
III	15 x 15 m

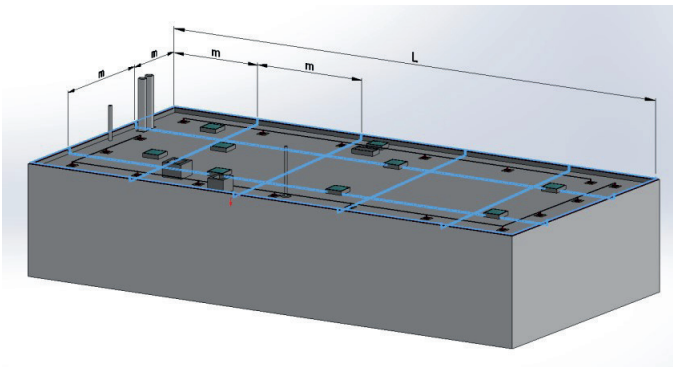

Application example  
Lightning protection on Contec.greenlight pro

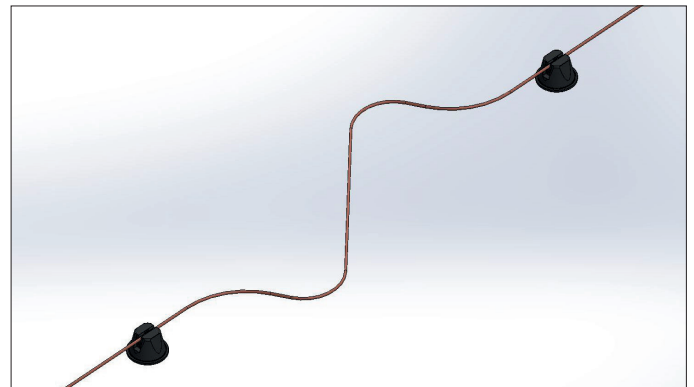

Expansion piece

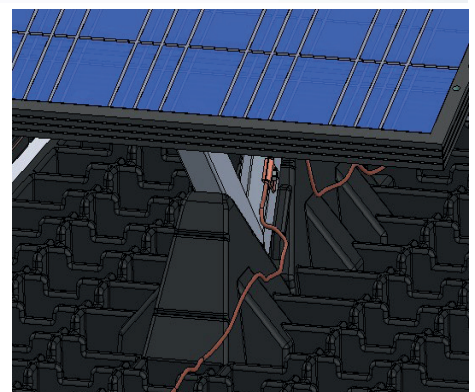
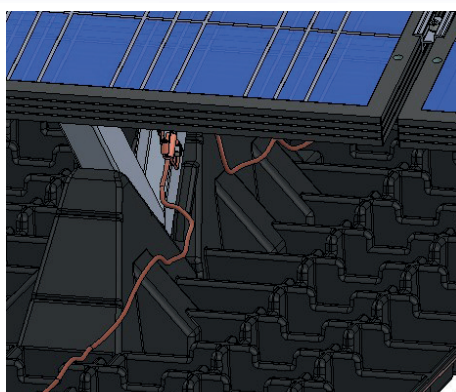
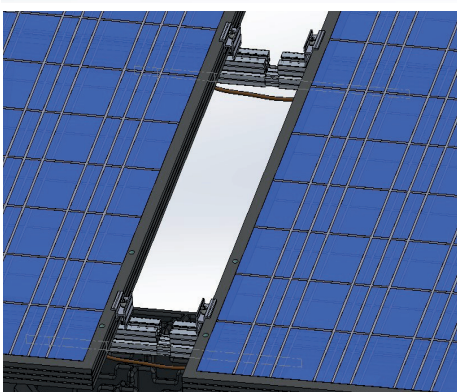
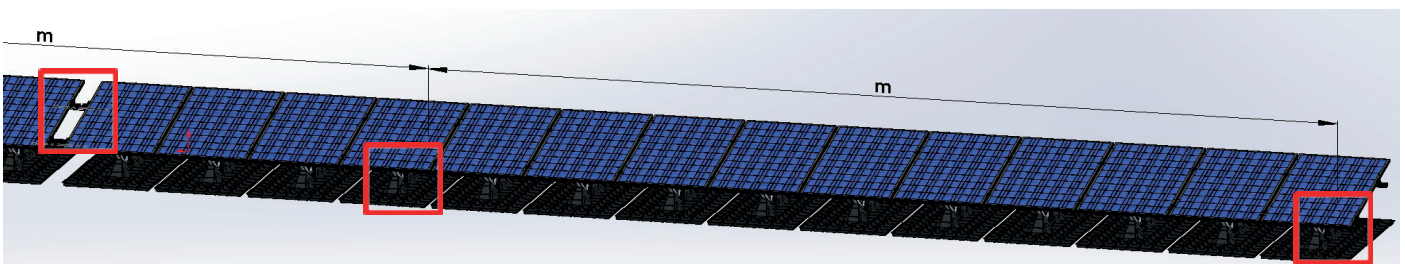



## Data sheet

# Contec.greenlight recommendation lightning protection

Conductivity aluminum profile rail part no.: 12.205.21

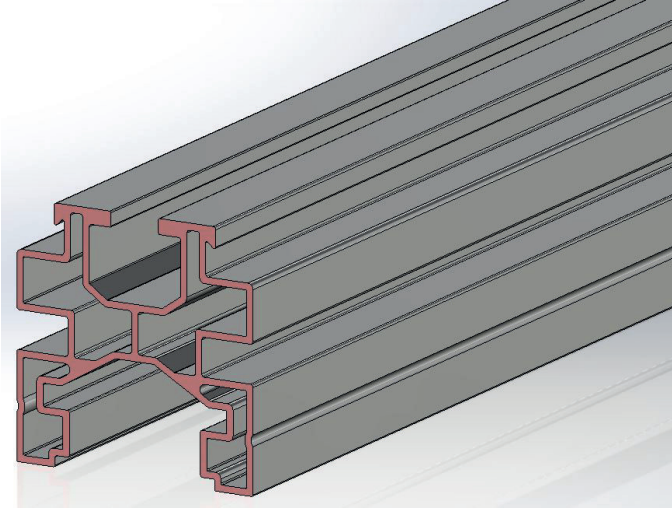

Profile rail universal  
Aluminium  
Item no.: 12.205.21  
EN AW- 6063-T66  
Area A = 405.8mm<sup>2</sup>

Calculation tool specific resistance Contec.greenlight aluminum

Contec.greenlight	Cross section	Spec. resistance	Spec. resistance
Profile length m	Contec.greenlight profile mm <sup>2</sup>	Aluminium Ω	Contec.greenlight profile Ω*mm <sup>2</sup> /m
6.10 m	305.80	0.03	1.85

The listed notes are recommendations for lightning protection with Contec.greenlight pro.

Lightning protection systems must comply with the legal standards DIN EN 62305 and VDE 0185-305:2006.

The obligation to install lightning protection systems is partly federally, partly cantonally regulated.

A lightning protection acceptance test is performed by a lightning protection officer/expert.

Lightning protection system check Status: September 2022

## Factsheet

### Contec.greenlight

#### Important information for a well-functioning EnergyGreenRoof

- Incorporate the Contec.greenlight system as early as the roof planning stage.
- The layered structure must be considered in the planning, because the substructure also serves as a water reservoir and drainage. This eliminates the need for additional products and reduces costs.
- The interfaces and workflows between the waterproofing contractor, the greening contractor and the solar installer must be clarified during the project phase.
- Responsibilities regarding maintenance, inspections and costs are to be clarified before the installation (landlord / tenant of roof areas).
- Before mounting, the mounting instructions as well as the mounting notes must be observed.
- Observe substrate installation thicknesses, substrate type and weights according to the plan.
- A special seed mixture must be used for the EnergyGreenRoof (low-growing).
- With the EnergyGreenRoof, at least 2 - 4 maintenance passes per year are necessary.
- When maintaining the green roof, make sure that no damage occurs to the PV systems.
- Tall growing plants are to be removed manually or with suitable equipment (no string mowers, as these could damage the power cables and contaminate the PV panels).
- Fall protection must be planned in accordance with the guidelines.

#### Advantages Contec.greenlight

- No yield loss due to shading of the plants (module height lower edge 30 cm from substrate)
- High biodiversity due to sun and shade situation
- Quick and easy assembly
- No accumulation heat under the panels, per 1° C cooler PV module, the additional power increases by 0.35 - 0.45 %.
- No roof penetration
- No additional superimposed loads necessary
- Integrated water reservoir in the substructure
- Simple integration of fall protection
- Optimal use of roof space
- Easy care, control and cleaning thanks to raised installation  
-> Approx. 50 % less maintenance required than with flat modules on fertilization
- Ecological added value of the flat roof thanks to the combination of PV and greening
- Snow slides quickly

# Factsheet

## Contec.greenlight

### Service Contec

We create

- Occupancy planning based on a layout proposal (initial planning free of charge, layout changes subject to a charge)
- Installation plan incl. load calculation

The planning of the Contec.safe fall protection system is taken into account.

On the roof

- Installation of the substructure and guardrails incl. acceptance tests
- Seeding with suitable seed
- Visual inspection PV plant
- Annual roof maintenance according to checklist
  - Maintenance greening
  - Check fall protection
  - Checking plumbing and connections
  - Cleaning PV panel

