

Assembly Instructions
Contec.greenlight on top 45° - 90°

(Standard, raised 75 cm, raised 90 cm)

26. 01. 2026



Contents

| | |
|---|---------|
| Technical information | 3 |
| Preparation | 4 |
| System components..... | 5 - 6 |
| Mounting Contec.greenlight on top 45° - 90° | 7 |
| Preparing the roof surface..... | 7 |
| Preparing the roof surface..... | 7 |
| Insert connectors to base rails..... | 7 |
| Position ballast unit | 8 |
| Pre-assembly of sliding profile, support profile, support strut | 8 |
| Connect support strut to sliding profile and support profile..... | 9 |
| Mounting pre-assembled profiles on base rail..... | 10 - 11 |
| Mounting profile rails..... | 12 - 13 |
| Assembly of wind bracing..... | 14 |
| Mounting anti-slip protection | 14 |
| Mounting the ballasting units | 15 |
| Mounting PV modules | 15 - 16 |

Technical information

| | |
|----------------------|---|
| Weight per unit | ~14.5 kg, weight without ballast, without PV module (landscape orientation) |
| Material | Magnelis, aluminum, stainless steel, galvanized steel |
| Standard module tilt | Adjustable to 45°, 60°, 75° and 90° |
| Roof connection | No structural connection to the roof required. Suitable for installation on green roofs and bare roofs. |
| Ballasting | Ballast load and distance between substructure components (spacing of base profiles / number of ballast units) must be calculated by Contec AG according to the wind zone plan. |
| Roof inclination | Inclination up to 5° is approved. For inclinations above 5°: approval only after technical clarification by Contec AG |
| Unit consists of | 1 x base rail according to installation plan 1 x support profile 1 x support strut 1 x sliding profile 2 x profile rails Small parts (slip protection, screws, L-shaped profile connectors, base rail connectors, module clamps) |
| Ballast unit | One ballast unit (top and bottom) filled with paving slabs according to the plan. Paving slabs: 50 cm x 50 cm (not included in the delivery) |
| Warranty | 10-year system warranty on Contec.greenlight on top 45° - 90° substructure ex works, valid from date of delivery. |

Preparation

To be considered:

- The existing roof surface or substructure must be thoroughly inspected in advance for damage, stability, and load-bearing capacity.
- The roof surface must be checked for evenness before installation (substrate with greenery or gravel surface). Uneven roof areas must be leveled, substrate/gravel added or removed as needed, and excessive vegetation must be cleared.
- Depending on the age of the roof surface, consultation and assessment by a roofer or qualified specialist is recommended.
- A detailed layout plan for the substructure can be obtained from the system planner.

Required tools for assembly



Torx-Bit TX40/45



13 mm ratchet socket wrench or 13 mm open-end wrench



Measuring tape 50 mm

System Components

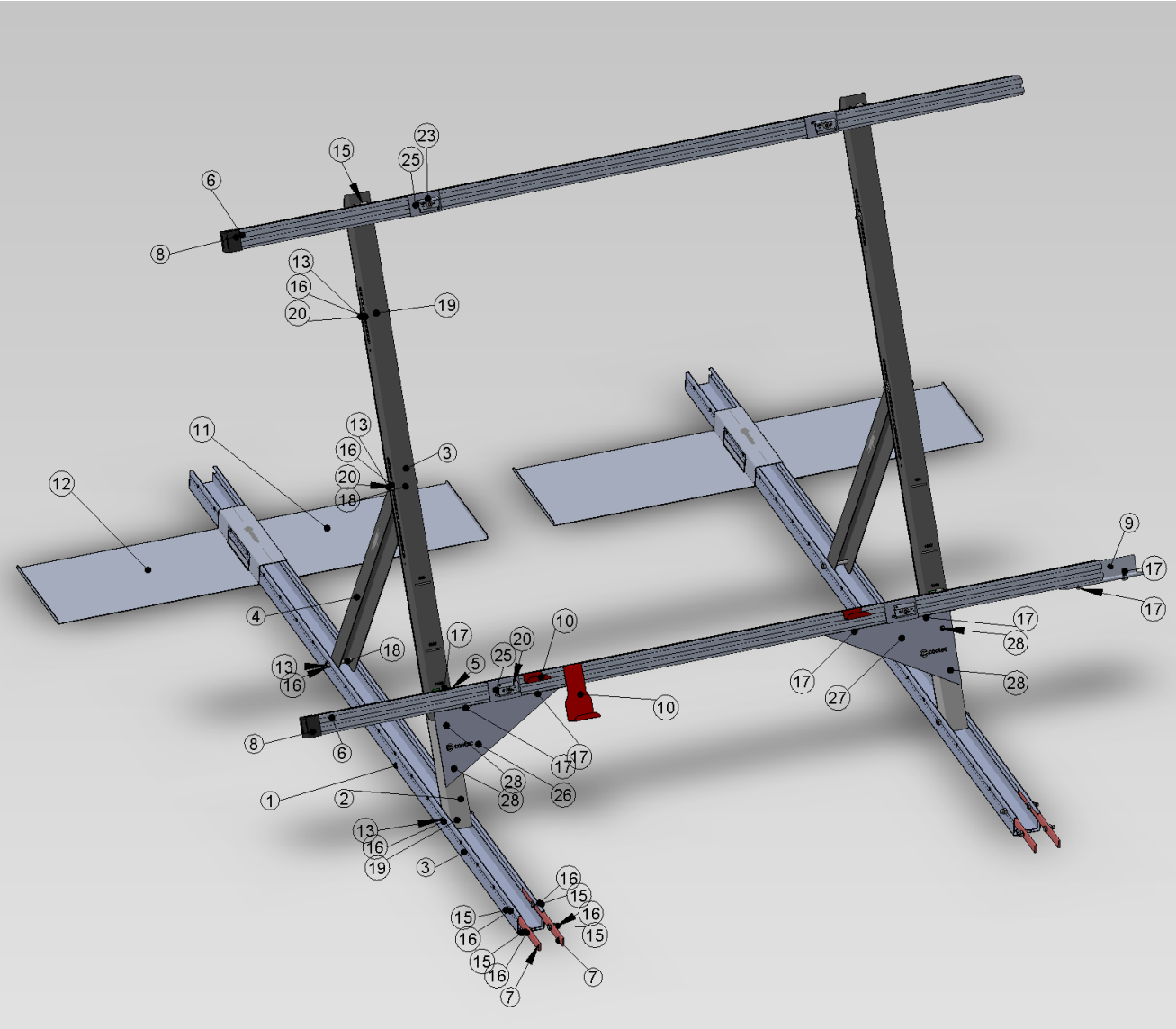

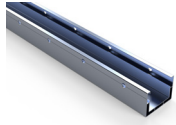

1
Base rail 3 m, 4.5 m, 6 m
Item No. 12.111.23-26



2
Support profile for sliding profile
Standard, elevated 75 + 90 cm
Item No. 12.311.21-29



3
Sliding profile 45° - 90°
Standard, elevated
Item No. 12.311.11-17



4
Support strut
Standard, elevated, 75cm + 90cm
Item No. 12.311.31-39



5
Profile bracket universal
Item No. 12.311.41

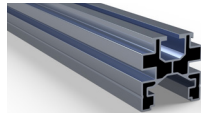

6
Profile rail 6.1 m
Item No. 12.400.21



7
Connector base rail
Item No. 12.111.31



8
End cap PE grey, black
Item No. 12.405.41-42

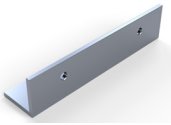

9
Profile connector L-shaped
Item No. 12.401.11



10
Anti-slip device long, universal
Item No. 12.406.70

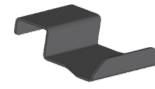

10
Anti-slip device short, universal
Item No. 12.406.71

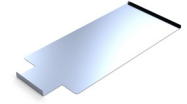

11
Ballast plate below
Item No. 12.111.48

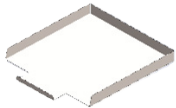

11
Ballast plate below, gravel
Item No. 12.111.47

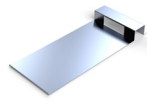

12
Ballast plate top
Item No. 12.111.45

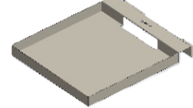

12
Ballast plate top, gravel
Item No. 12.111.43



13
Hexagon head screw M8 x 80
Item No. 12.411.27

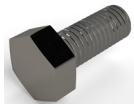

15
Hexagon head screw M8 x 20 mm
Item No. 12.411.20

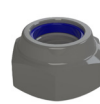

16
Hexagon nut M8
Item No. 12.411.35



17
Pan head screw M8 x 20 mm
thread-forming
Item No. 12.410.20



18
Bushing ø 12 mm, Length 43 mm
Item No. 12.411.43



19
Bushing ø 12 mm, Length 47 mm
Item No. 12.411.47



20
Washer M8
Item No. 12.411.32

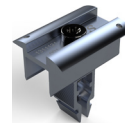

21
Center clamp 30 - 40 mm
Torque 15 Nm
Item No. 12.500.05 (silver)
Item No. 12.500.15 (black)

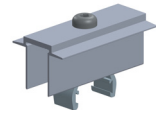

21
Module holder AK II Click
30 - 50 mm
Item No. 12.500.07 (silver)
Item No. 12.500.17 (black)

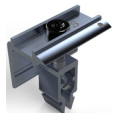

23
End clamp 30 - 40 mm
Torque 15 Nm
Item No. 12.501.05 (silver)
Item No. 12.501.15 (black)



23
End clamp AK II Click 30 - 50 mm
Item No. 12.501.07 (silver)
Item No. 12.501.17 (black)

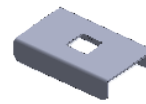

25
Mounting plate for module clamp
Item No. 12.406.80



26
Wind bracing 45° - 90°, left
Item No. 12.311.45



27
Wind bracing 45° - 90°, right
Item No. 12.311.46



28
Self-drilling screw, 4.8 x 20 mm A2
Item No. 12.411.29

Assembly Contec.greenlight on top 45° - 90°

Prepare the roof surface

- Level uneven roof surfaces and add or remove substrate/gravel as needed.
- Remove excessive vegetation.

Lay base rails

- Position the base rails on the roof surface according to the project-specific installation plan.
- Ensure the base rails are parallel.

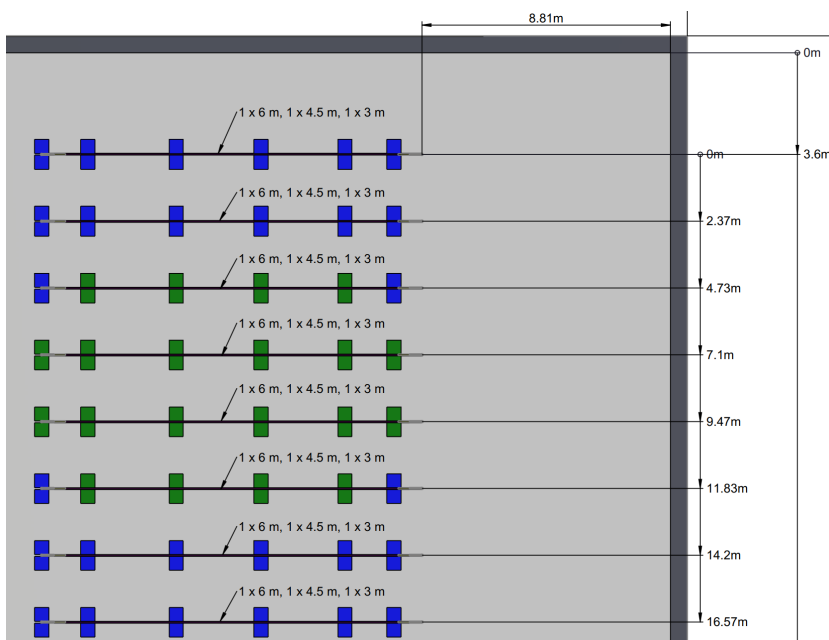

Insert connectors into base rails

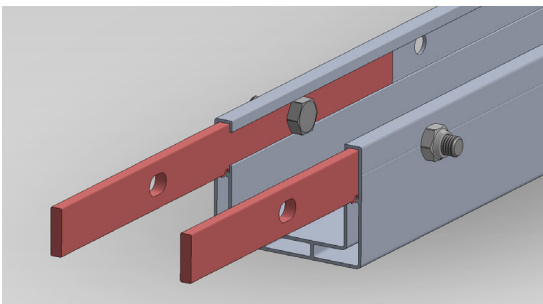

- Install the base rail precisely according to the installation plan and comply with all relevant specifications.
- Connect the base rails using the connectors.
- Mount M8 x 20 hex metal bolts from the inside to the outside.
- The bolt is secured through the base rail profile.
- Tighten the M8 locknut.

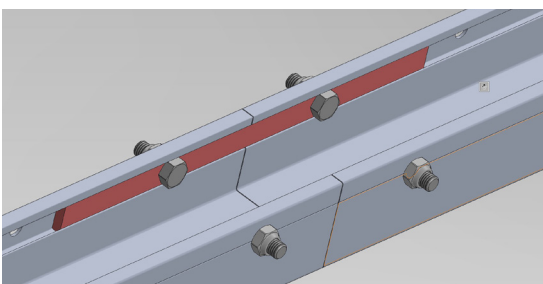

Place the ballast unit

- To stabilize the base rails, a ballast unit is installed at the beginning and end of each row, without using paving slabs at this stage
- The paving slabs will only be placed after the entire system has been fully assembled.

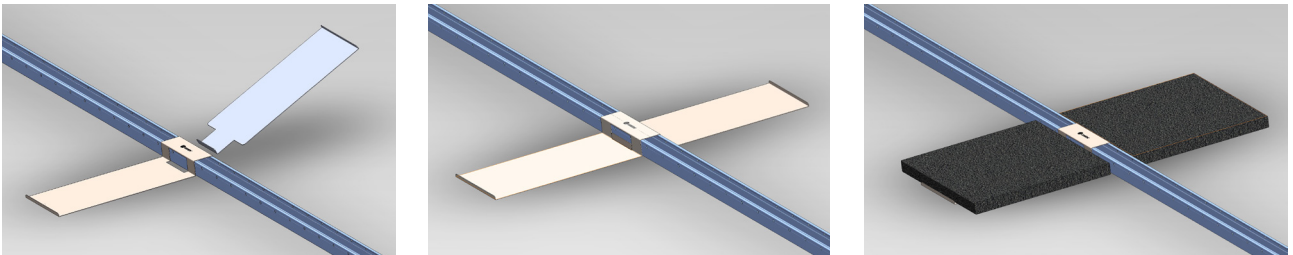

Pre-assembly of sliding profile, load-bearing profile, and support strut

Tip: Bring a table or a pallet with a double frame and cover as an assembly aid to make the work easier.

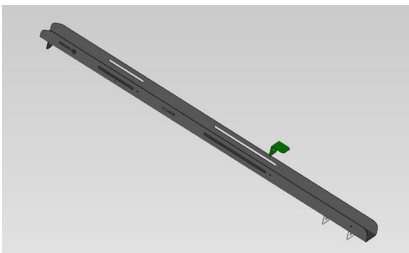

- Lay the sliding profile on the surface and align it.
- Insert and securely fix the profile holder according to the plan documents.

900 mm for landscape clamping

1057 mm for bifacial clamping of special modules

1150 mm for bifacial clamping, module width 1134 mm

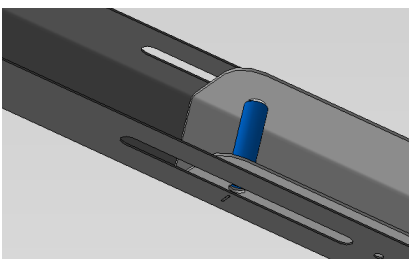
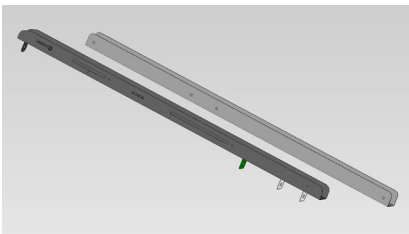

- Insert the support profile into the sliding profile and align it carefully.
- Position and insert the sleeve with a diameter of 12 mm and a length of 47 mm into the top hole.

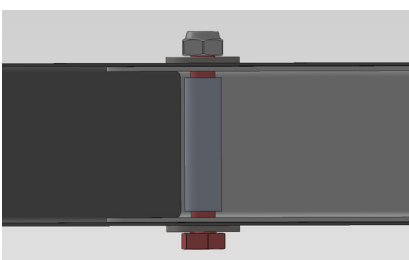

- Connect the sliding profile and the support profile at the top hole using an M8 x 80 hex metal bolt and an M8 locknut. Place one M8 washer under both the bolt head and the locknut.
- Tighten the M8 locknut.

Connect the support strut to the sliding profile and the support profile

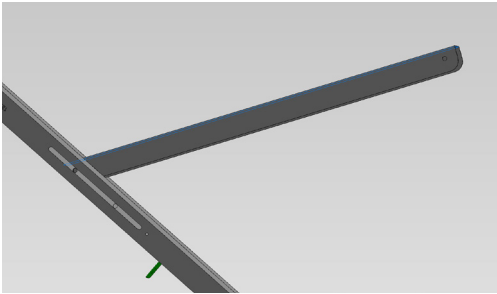

- Mount the support strut in the designated hole according to the plan documents or the table below, and pay attention to the labeling.

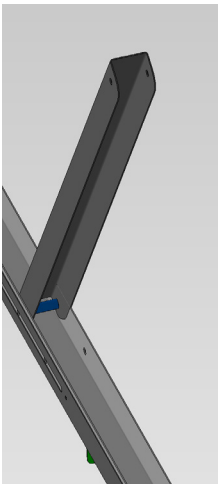

- Position and insert the sleeve with a diameter of 12 mm and a length of 43 mm into the hole

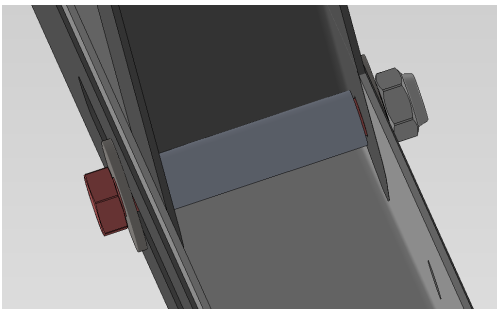

- Connect the support strut using an M8 x 80 hex bolt and an M8 locknut.
- Place an M8 washer under both the bolt head and the locknut.

Mounting pre-assembled profiles onto the base rail

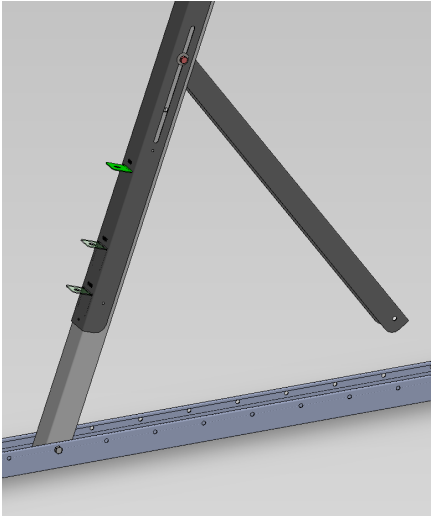

- Position the pre-assembled components according to the installation plan, aligning the support profile according to the specified dimensions.
- Insert the sleeve with a diameter of 12 mm and a length of 47 mm into the support profile, ensuring it is precisely aligned with the hole.
- Mount the support profile to the base rail using an M8 x 80 hex bolt and an M8 locknut, and tighten firmly.
- Insert the sleeve with a diameter of 12 mm and a length of 43 mm into the support strut, ensuring it is precisely positioned over the hole.
- Mount the support strut to the base rail using an M8 x 80 hex bolt and an M8 locknut. Tighten the connection form-fit so that the base rail is deformed slightly, ensuring a stable and permanent connection.
- Install additional units according to the installation plan and the grid spacing $x =$.

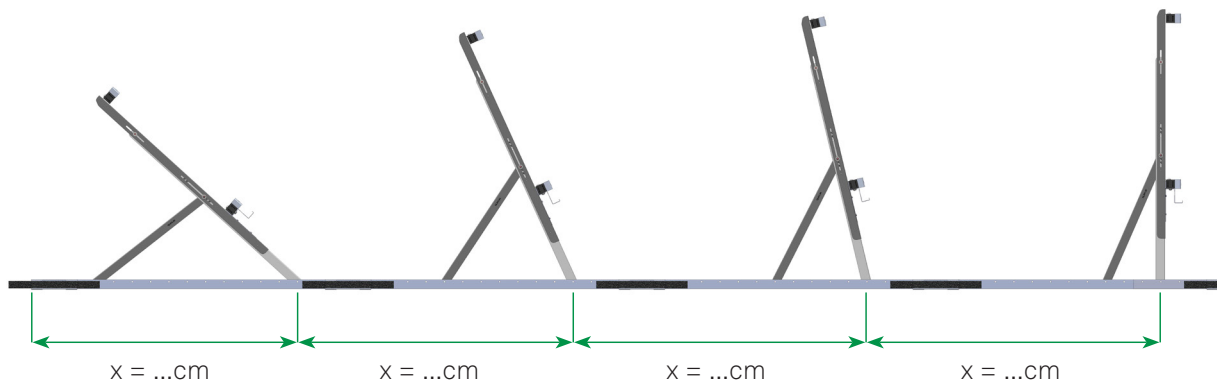

| Elevation Contec.greenlight on top 45° - 90° | Hole 45° - 60° (top) | Hole 75° - 90° (bottom) | Distance between central bolt / support strut on base rail |
|--|-------------------------|----------------------------|---|
| Standard | | | |
| 45° | x | | 1100 mm |
| 60° | x | | 700 mm |
| 75° | | x | 500 mm |
| 90° | | x | 300 mm |
| 75 cm elevated | | | |
| 45° | not possible | not possible | not possible |
| 60° | x | | 800 mm |
| 75° | | x | 700 mm |
| 90° | | x | 400 mm |
| 90 cm elevated | | | |
| 45° | not possible | not possible | not possible |
| 60° | x | | 900 mm |
| 75° | | x | 700 mm |
| 90° | | x | 400 mm |

Mounting profile rails

- Tip: Use a clamp as an assembly aid.
- Caution: For elevated systems, always use a ladder. To avoid accidents or damage, never use the lowest profile rail as a step!

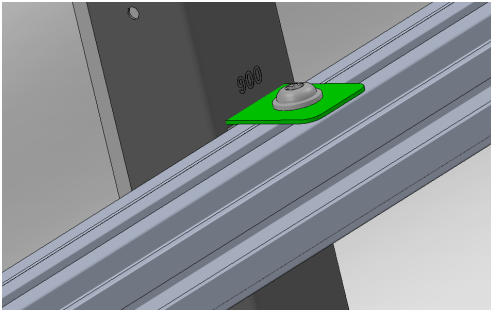

- Mount the profile rail to the profile holder using an M8 x 20 thread-forming pan head screw.
- Tighten the screw with a cordless screwdriver until the profile rail sits flush against the profile holder and is firmly secured.

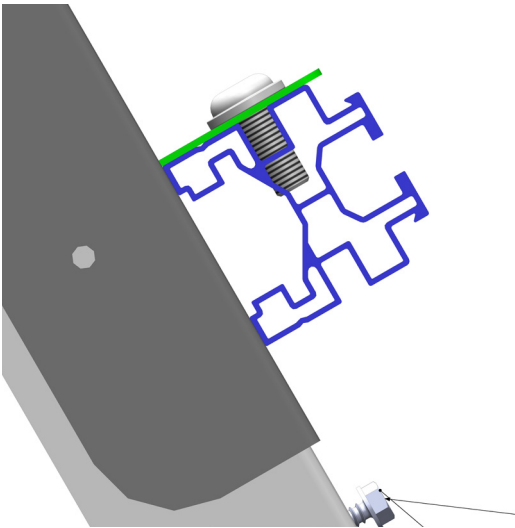

- Mount the profile rail at the elevated position (bend) using an M8 x 20 thread-forming pan head screw.

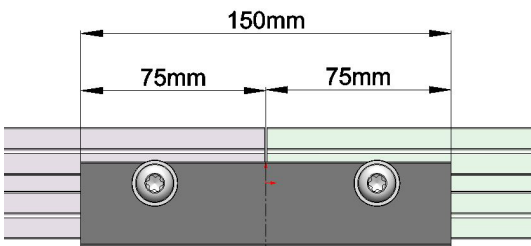

- Connect the profile rails using an L-shaped profile connector and an M8 x 20 thread-forming pan head screw.

- Mount the profile rails alternately as specified.
Important: Install the profile rail exactly as shown in the following image, as the number of profile rails is calculated based on the specified installation layout.
- The profile rail length is calculated using the formula:
(Module width + Clamp width) x Number of modules per row + 100 mm (row start)
+ 100 mm (row end)



Mounting the wind brace

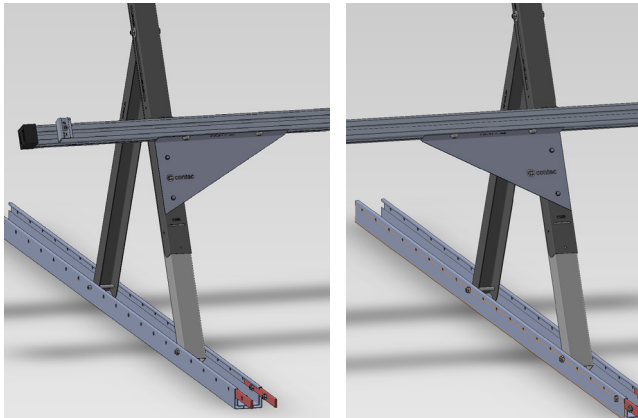

- Install the wind brace on both the right and left sides of each row, at both the beginning and the end.
- Use 2 M8 x 20 thread-forming pan head screws and 2 hex head self-drilling screws $\varnothing 4.8 \times 20$ mm for each connection.

Mounting the anti-slip device

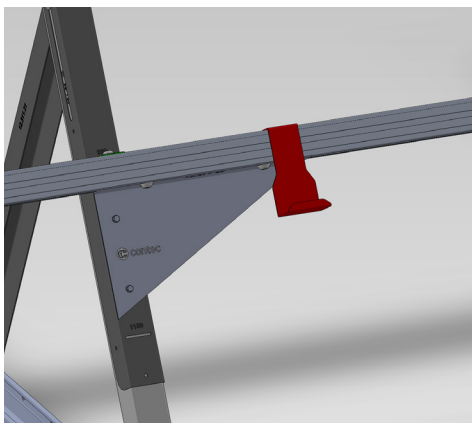

- Place 2 slip guards (long or short) per module onto the lower profile rail.
No screws are required for fastening.
- Use the long slip guard for modules in landscape clamping (with module clamps on the short side of the module), placing it on the lower profile rail.

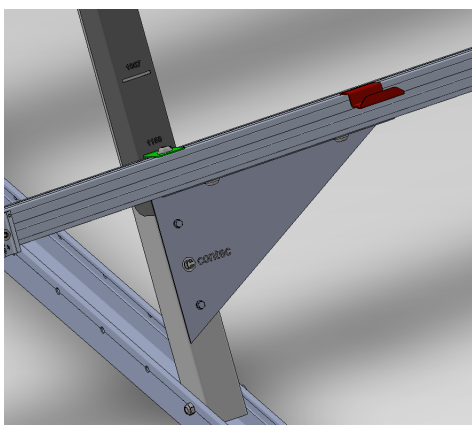

- Place the short slip guard on the lower profile rail for modules with bifacial clamping (clamping on the long side of the module, ¼-point clamping).

Mounting ballast units

- Paving slabs are **not** included in the delivery.
- Arrange the ballast units according to the installation plan.
 - The indicated positions of the ballast units are symbolic and may be adjusted laterally on the base rail in case of collisions. Ballast plates at the beginning and end of the base rail should be positioned so that the concrete slabs and the base rail are flush.
 - For structural stability, use concrete slabs with dimensions of 50 cm x 50 cm x 4 cm and a minimum weight of 21 kg per piece.
- Distribute the concrete slabs evenly according to the installation plan, paying attention to possible colour variations in the ballast units.
- The maximum spacing between ballast units on the base rail is 3 meters.

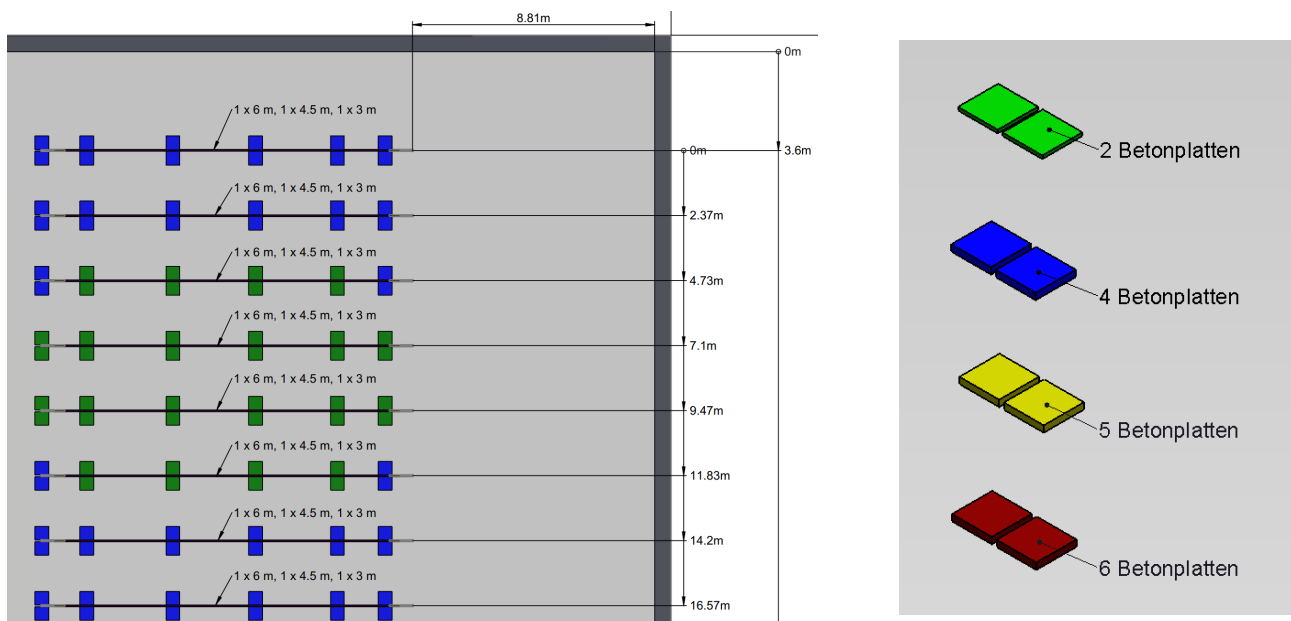

Mounting PV modules

- Only clamping systems approved by Contec AG may be used for assembly.
- The tightening torque (MA) of the module clamps must be checked and applied correctly according to the manufacturer's specifications. Insufficient torque may cause system failure and compromise the stability of the entire structure.
- Any installation of modules that deviates from Contec AG's planning is only permitted with prior coordination and written approval from the manufacturer.
- Upon order confirmation, Contec AG assumes responsibility for the system's structural analysis.
- However, the customer is responsible for obtaining static approval of the roof area to be used.
- Only framed modules may be installed. Compliance with the module clamping zones and approval of the fastening method is the responsibility of the PV system installer. Manufacturer approval may be required.
- Contec AG accepts no liability if the module manufacturer's specifications are not followed. It is the installer's responsibility to ensure that all manufacturer requirements are met to guarantee the safety and functionality of the installation.

Landscape Clamping Installation

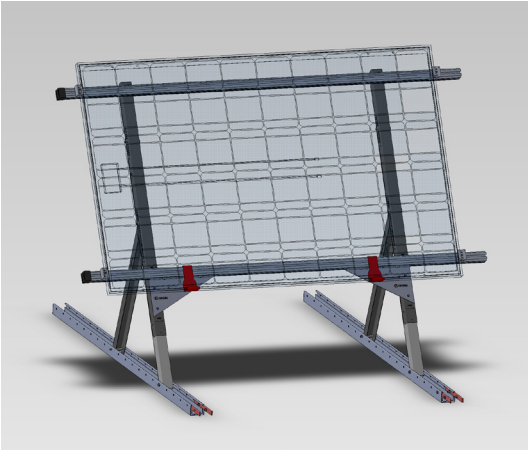

- Clamp the modules on the short frame side.
- Install the rail continuously underneath the module, parallel to the long module edge.
- Tighten the module clamps according to the specifications provided by the clamp manufacturer.

Bifacial Clamping Installation

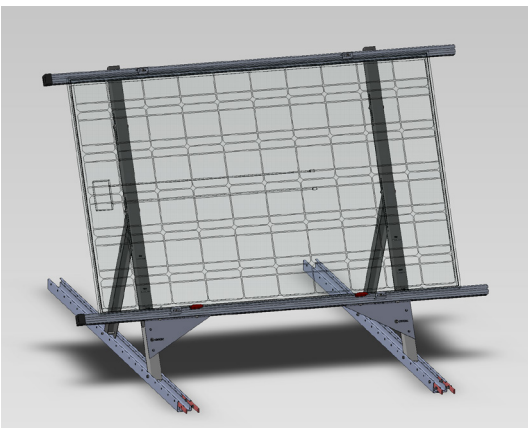

- Clamp the modules on the long side.
- Install the profile rail continuously beneath the frame, parallel to the long module edge.

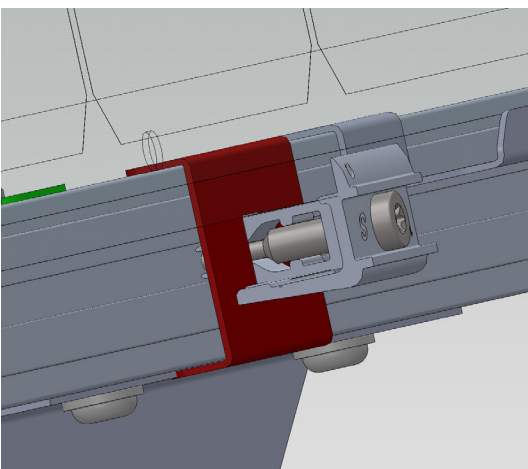

- Place the universal backing plate over the profile rail at each module clamp position.
- Click the module clamp into the designated slot of the profile rail.
- Tighten the module clamps according to the specifications provided by the clamp manufacturer (Schletter).

Contec.greenlight on top 45° - 90°
The solution for the EnergyGreenRoof.

