



Assembly instruction
Contec.greenlight on top

Version september 2024



Table of contents

Technical information3

Preparation4

System components 5 - 7

Work step 1..... 8 - 10

Work step 2..... 11

Work step 3..... 12

Work step 4.....13 - 14

Work step 5..... 15

Work step 6..... 16

More hints17 - 19

Technical information

Contec.greenlight on top	For one unit - L =	~1.5 m base rail (landscape) ~2.1 m base rail (portrait)
Weight per unit		9.3 kg, weight without ballast, without PV module (landscape)
Material		Magnelis, aluminum, stainless steel, galvanized steel
Standard module inclination		10°, 15°, 20° standard (freely adjustable)
Roof connection		No structural roof connection required, for installation on green roof surfaces and bare roofs
Ballasting		Contec AG must calculate the superimposed load and the spacing of the substructure (spacing of the Knickfix base profile) in accordance with the wind zone plan. be calculated according to the wind zone plan.
Roof pitch		Inclination up to 5° approved. From 5°: Approval only with technical clarification by Contec AG.
Unit consists of	Landscape:	1 x ~1.5 m Base rail 1 x ~3.5 m Profile rail
	Portrait:	1 x ~2.1 m Base rail 1 x ~2.2 m Profile rail
	Universell:	1 x Knickfix 1 x Fixed strut Small items (screws, L-shaped profile connectors, base rail connectors, module clamps)
Ballasting unit		Garden slabs 50 cm x 50 cm (not included in the scope of delivery)
Warranty		10 year system warranty on Contec.greenlight on top substructure ex works, valid from date of delivery

Preparation

Please note:

- The existing roof surface or substructure must be thoroughly checked for damage, stability and load-bearing capacity beforehand.
- The roof surface (substrate with greenery or gravel surface) must be checked for evenness before installation. Uneven roof surfaces must be repaired, substrate/gravel refilled or removed and strong plant growth removed.
- A detailed design of the substructure can be obtained from the plant designer.

Required tools and materials for assembly



Inbus insert size: 5 mm
(S:Flex module clamps)



Torx insert size: TX40
(Schletter module clamps)



2 pcs. hexagonal insert size: SW 13 mm



Torque wrench 15 - 20 Nm

System components

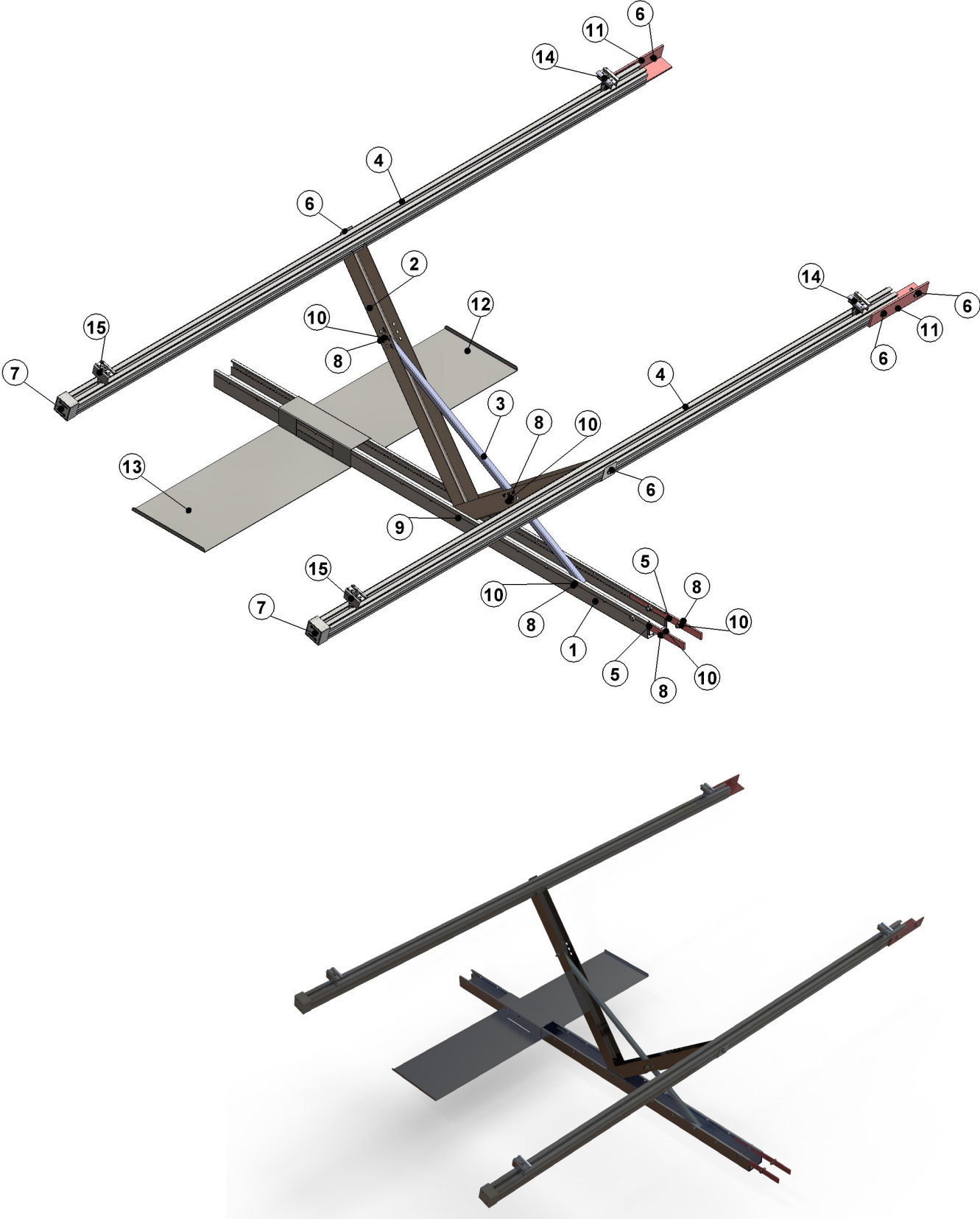

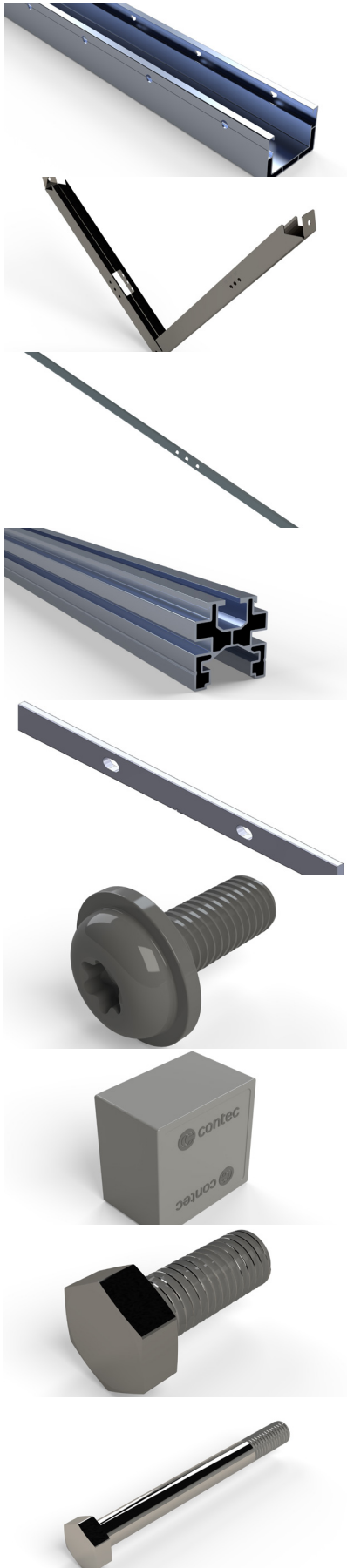

<p>Pos. 1 Base rail (perforated)</p>	<p>Item no. 12.101.23 12.101.24 12.101.25</p>	<p>approx. 1.5 m/unit (landscape) approx. 2.1 m/unit (portrait)</p>
<p>Pos. 2 Knickfix (10 - 20° standard / 5 - 45° optional)</p>	<p>Item no. 12.200.41</p>	<p>1 pcs/unit</p>
<p>Pos. 3 Fixed strut</p>	<p>Item no. 12.200.45</p>	<p>1 pcs/unit</p>
<p>Pos. 4 Profile rail</p>	<p>Item no. 12.205.11/21</p>	<p>approx. 3.5 m/unit (Landscape) approx. 2.2 m/unit (Portrait)</p>
<p>Pos. 5 Connector base rail</p>	<p>Item no. 12.101.26</p>	<p>2 pcs/interface</p>
<p>Pos. 6 Pan head screw (M8 x 20 thread grooving)</p>	<p>Item no. 12.400.20</p>	<p>2 pcs/unit</p>
<p>Pos. 7 End cap PE</p>	<p>Item no. 12.305.41</p>	<p>4 pcs/row</p>
<p>Pos. 8 Hexagon head screw M8 x 20 mm</p>	<p>Item no. 12.400.25</p>	<p>3 pcs/unit 2 pcs/connector base rail</p>
<p>Pos. 9 Hexagon head screw M8 x 75/80 mm</p>	<p>Item no. 12.400.27</p>	<p>1 pcs/unit</p>

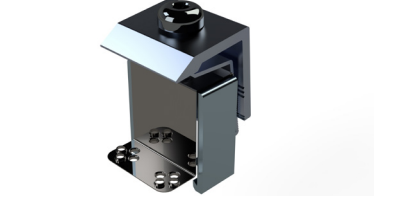
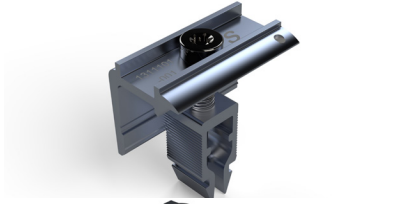
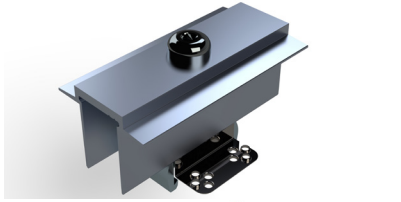
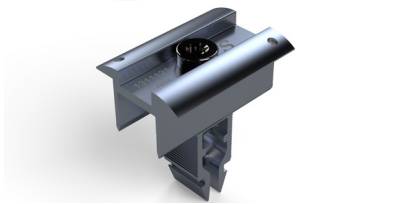
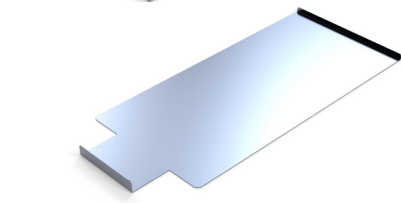
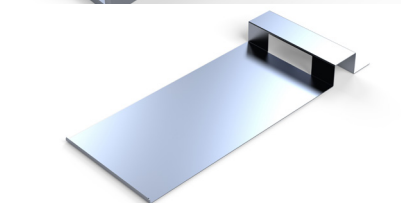
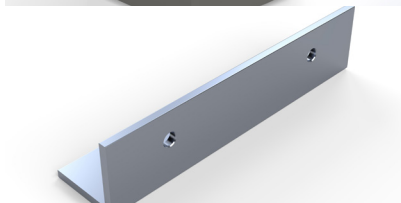
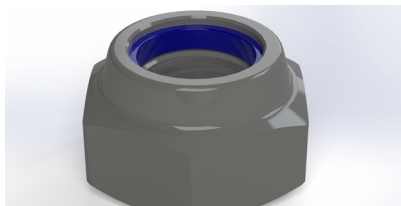

<p>Pos. 10 Hexagon nut M8 (with polyamide ring)</p>	<p>Item no. 12.400.29</p>	<p>3 pcs/unit 2 pcs/connector Base rail</p>
<p>Pos. 11 Profile connector L-shaped</p>	<p>Item no. 12.305.11</p>	<p>1 piece/profile rail</p>
<p>Pos. 12 Ballast plate top</p>	<p>Item no. 12.101.27</p>	<p>Pcs. according to specification</p>
<p>Pos. 13 Ballast plate below</p>	<p>Item no. 12.101.28</p>	<p>Pcs. according to specification</p>
<p>Pos. 14 Center clamp $M_A = \text{max. } 16 \text{ Nm}$</p>	<p>Item no. 12.300.11/12</p>	<p>Pcs. according to PV layout</p>
<p>Pos. 14 Center clamp $M_A = \text{max. } 10 \text{ Nm}$</p>	<p>Item no. 12.300.12</p>	<p>Pcs. according to PV layout</p>
<p>Pos. 15 End clamp $M_A = \text{max. } 16 \text{ Nm}$</p>	<p>Item no. 12.301.05</p>	<p>Pcs. according to PV layout</p>
<p>Pos. 15 End clamp $M_A = \text{max. } 10 \text{ Nm}$</p>	<p>Item no. 12.301.06</p>	<p>Pcs. according to PV layout</p>

Work step 1

Setting up the Contec.greenlight on top base rail mounted with Knickfix

- Repair uneven roof surfaces. Backfill or remove substrate/gravel. Remove heavy plant growth.
- Place base rail with pre-assembly (position Knickfix) on the roof surface.
- The edge distances, the distances of the Knickfix X as well as the distances for the base rails (Y see page 17), are to be taken from the planning documents (installation plan with order).



Variant east / west orientation -> butterfly shape

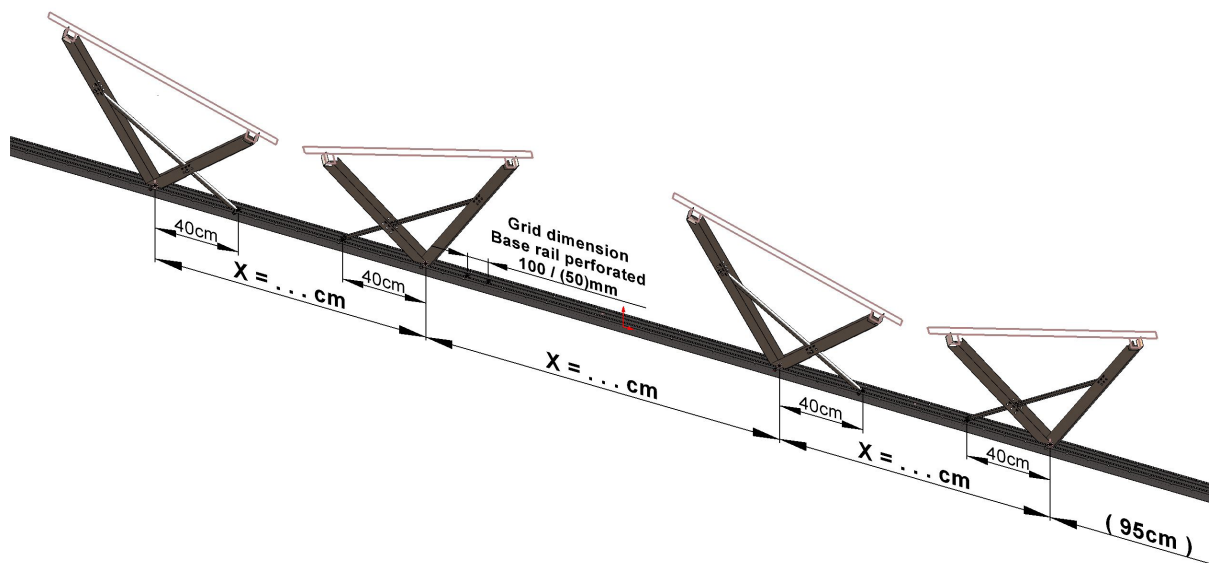

Mounting Contec.greenlight Knickfix with fixed struts on base rails

- Mount Knickfix with fixed strut on base rail

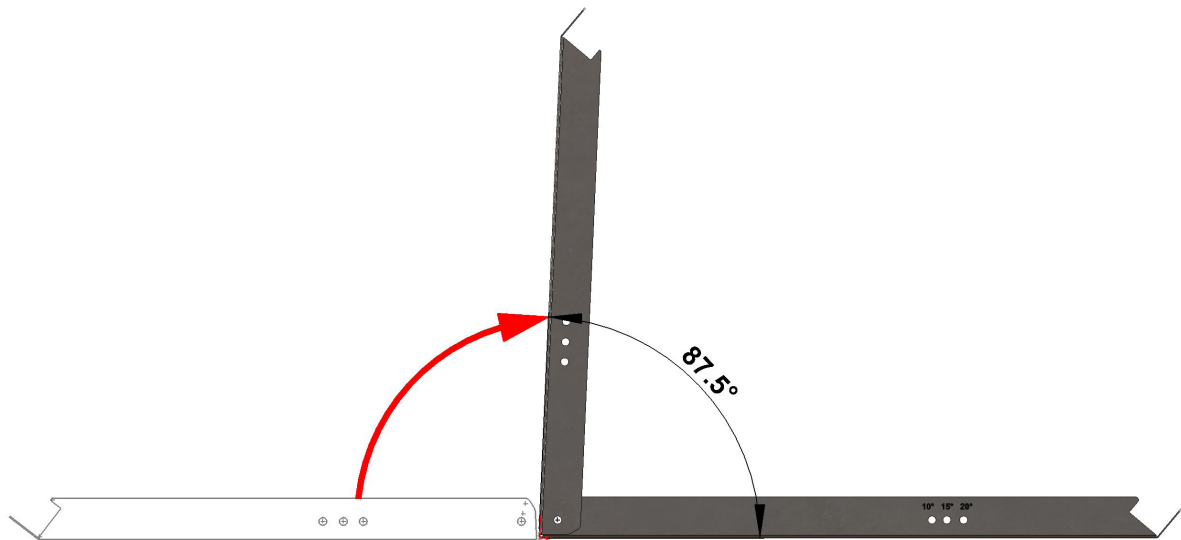

- The Knickfix angle is bent by hand to 87.5°.
- The angle is then positioned on the base rail at the specified distance and screwed in place.
- Mount fixed strut: 10°, 15° or 20° standard -> freely adjustable
- Place the screws in the position for desired angle of inclination.

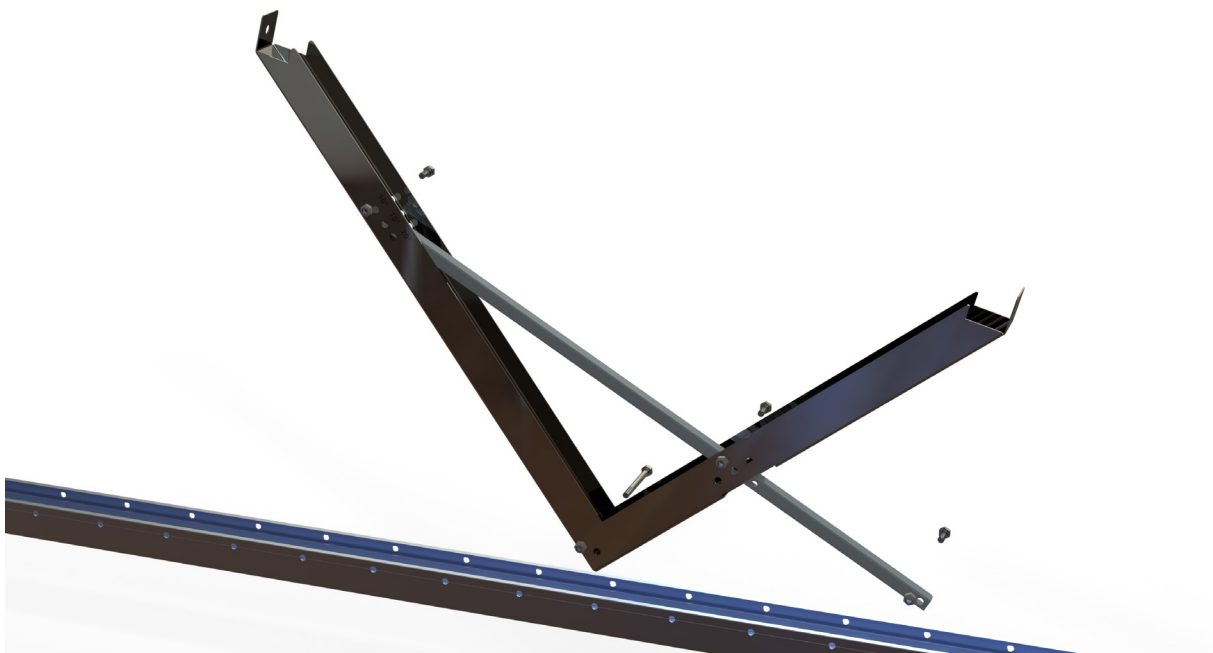

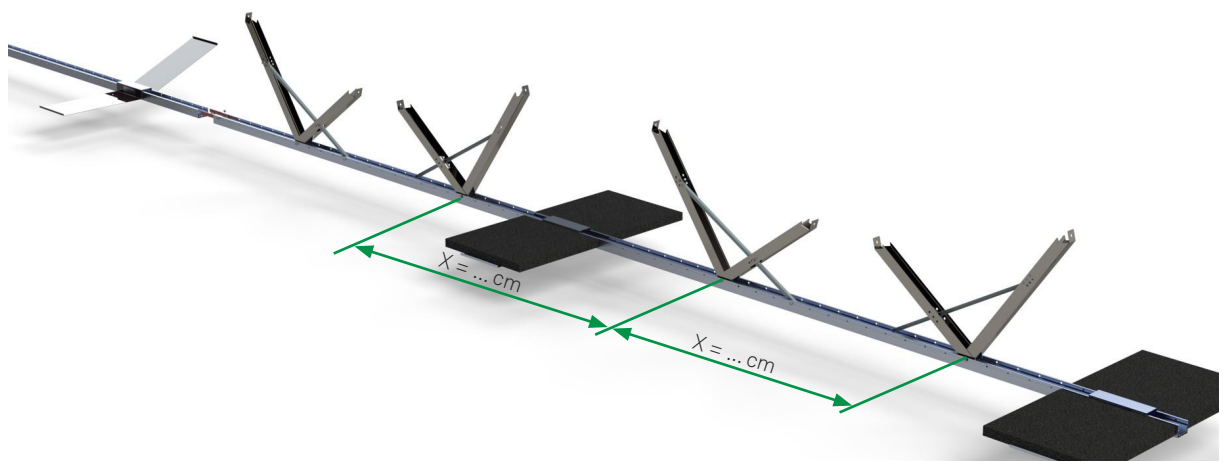
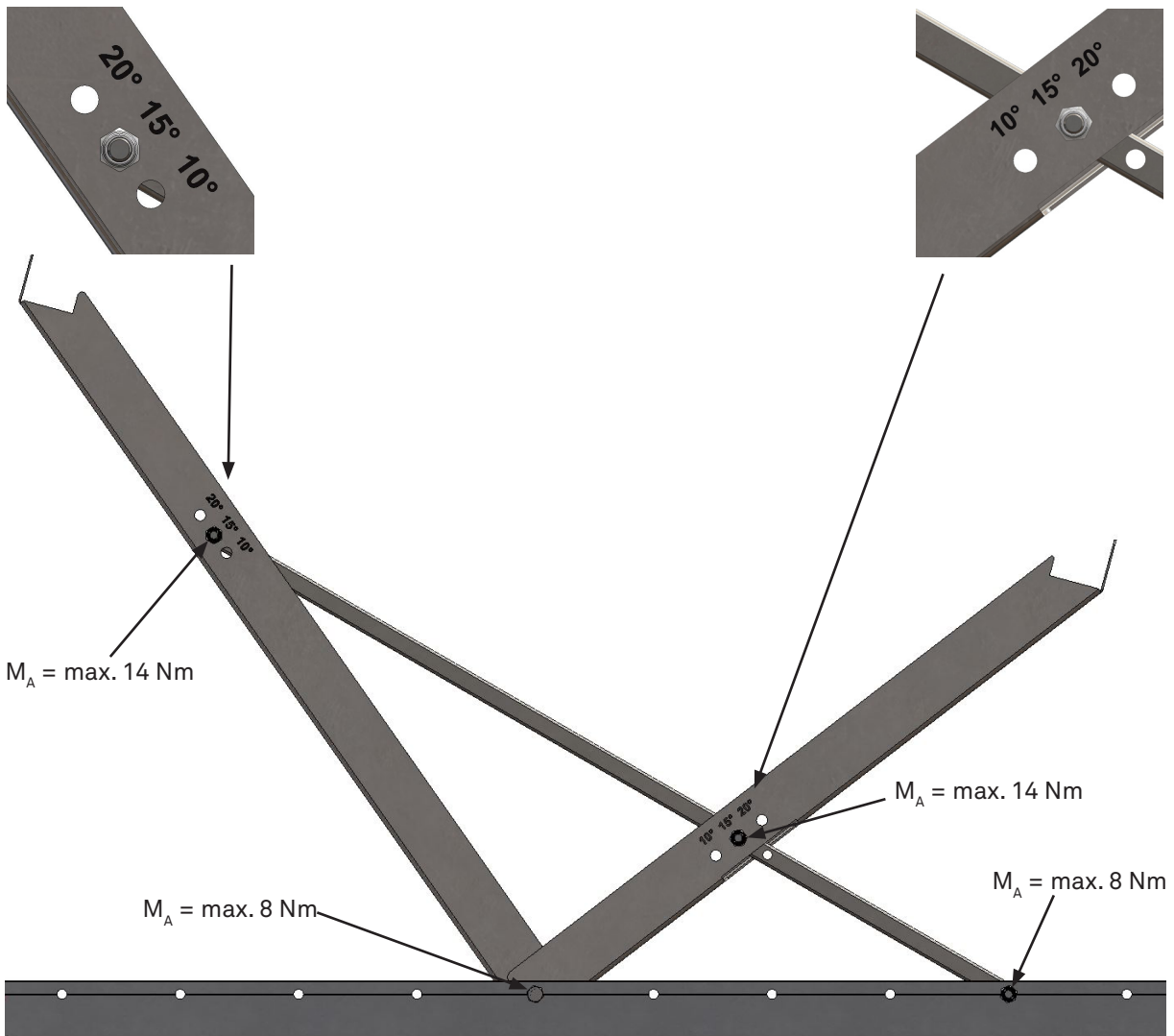

Work step 2

Connector base profile

- 2 pcs. Connector base profile per interface
- Screw on hexagon head screw M8 x 20 mm (4 pcs.) ($M_A = \text{max. } 14 \text{ Nm}$)

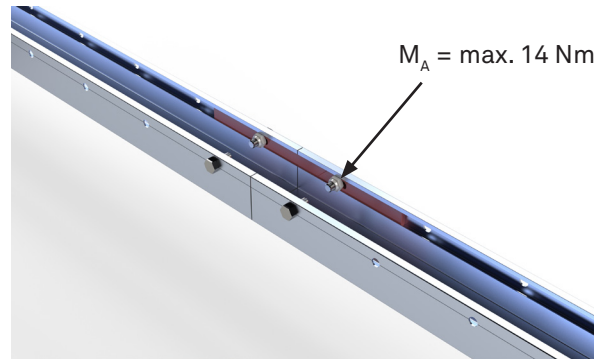
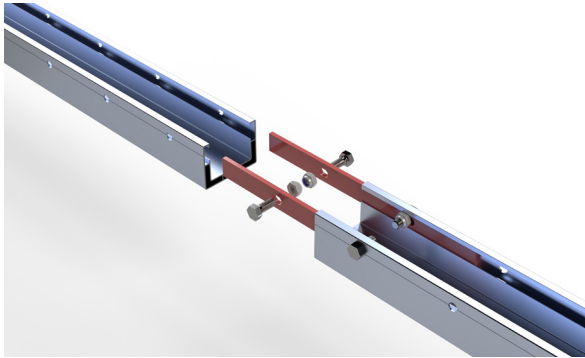

Connector base profile

- Mount the ballast plate at the top and bottom.
- Ballasting with garden plate 1x 2 pcs. = $\geq 42 \text{ kg}$ / 2x 2 pcs. = $\geq 84 \text{ kg}$
- The distances of the ballasting units are to be taken from the planning documents (installation plan).

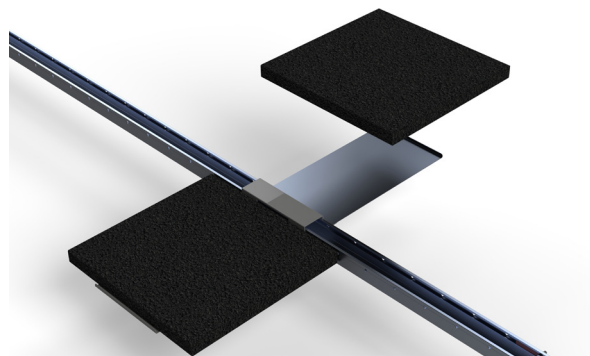
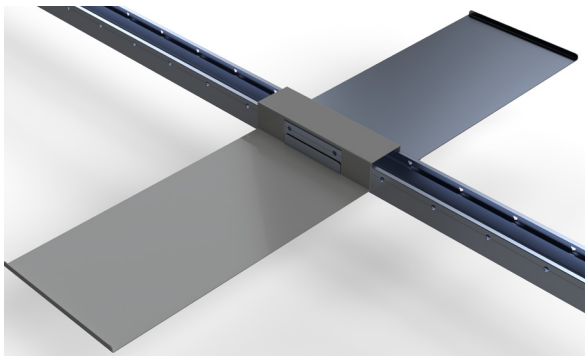
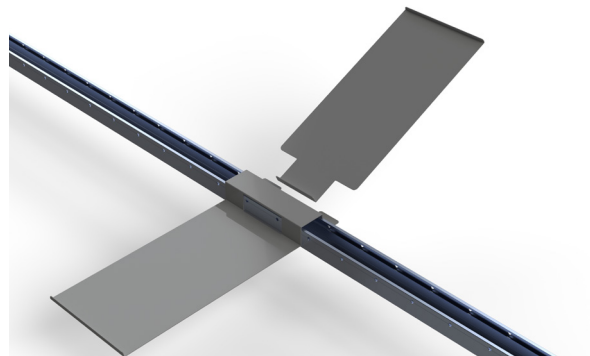
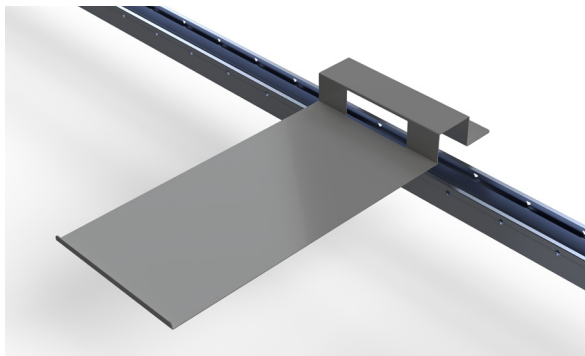

Garden plates are not included in the delivery.

Work step 3

Setting up/positioning the preassembled base rail with Knickfix and fixed strut

- Place the pre-assembled base rail on the roof surface. The grid dimension Y of the base rail can be found in the planning documents (installation plan).
- Ensure that the base rail is parallel to each other and that the Knickfix is in the correct position.

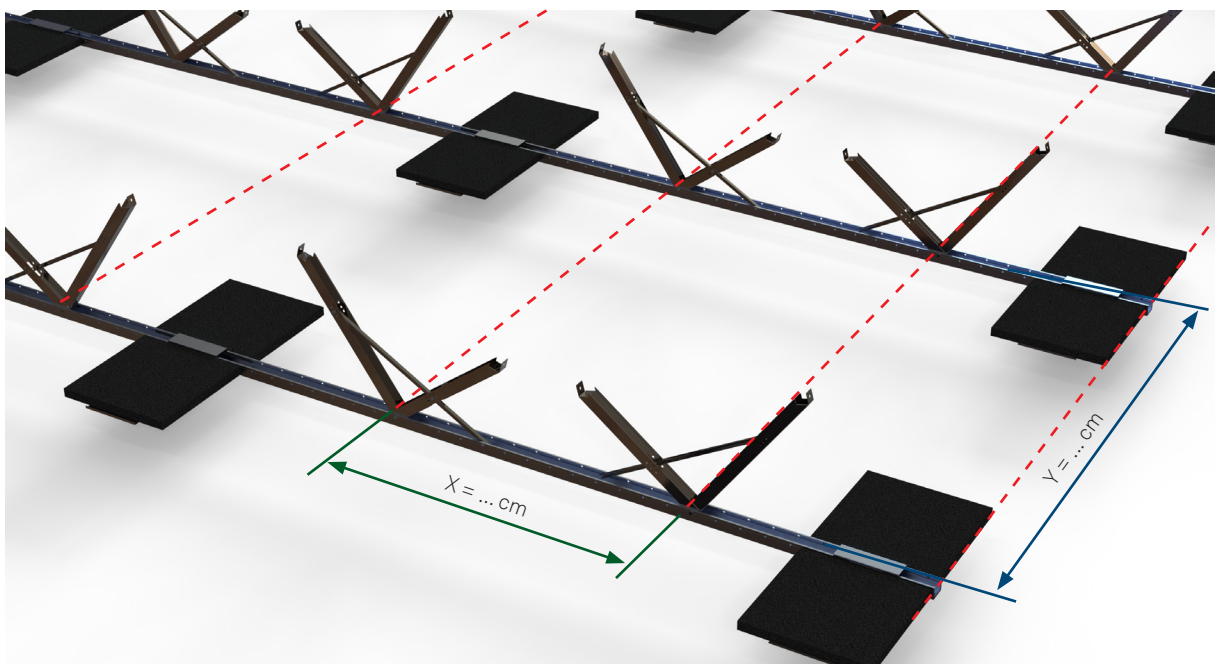
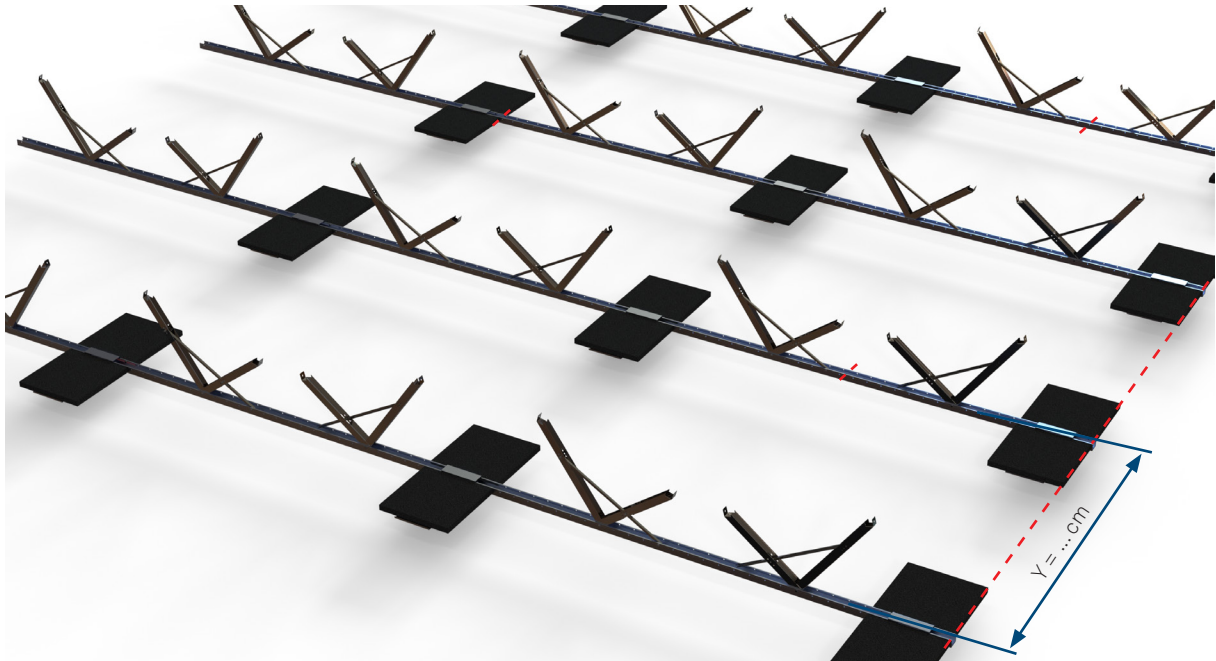

- Check alignment distance of Knickfix (base position of hexagon head screw M8 x 75/80 mm)
- Check parallelism of the base rail to each other

Work step 4

Mounting the profile rails

Now the individual profile rails can be screwed onto the Knickfix brackets with the thread-forming screws M8 x 20 mm screws. Without pre-drilling, with the correct torque of the drilling machine, the screws should penetrate the profile wall (with feeling and at the same time some pressure).

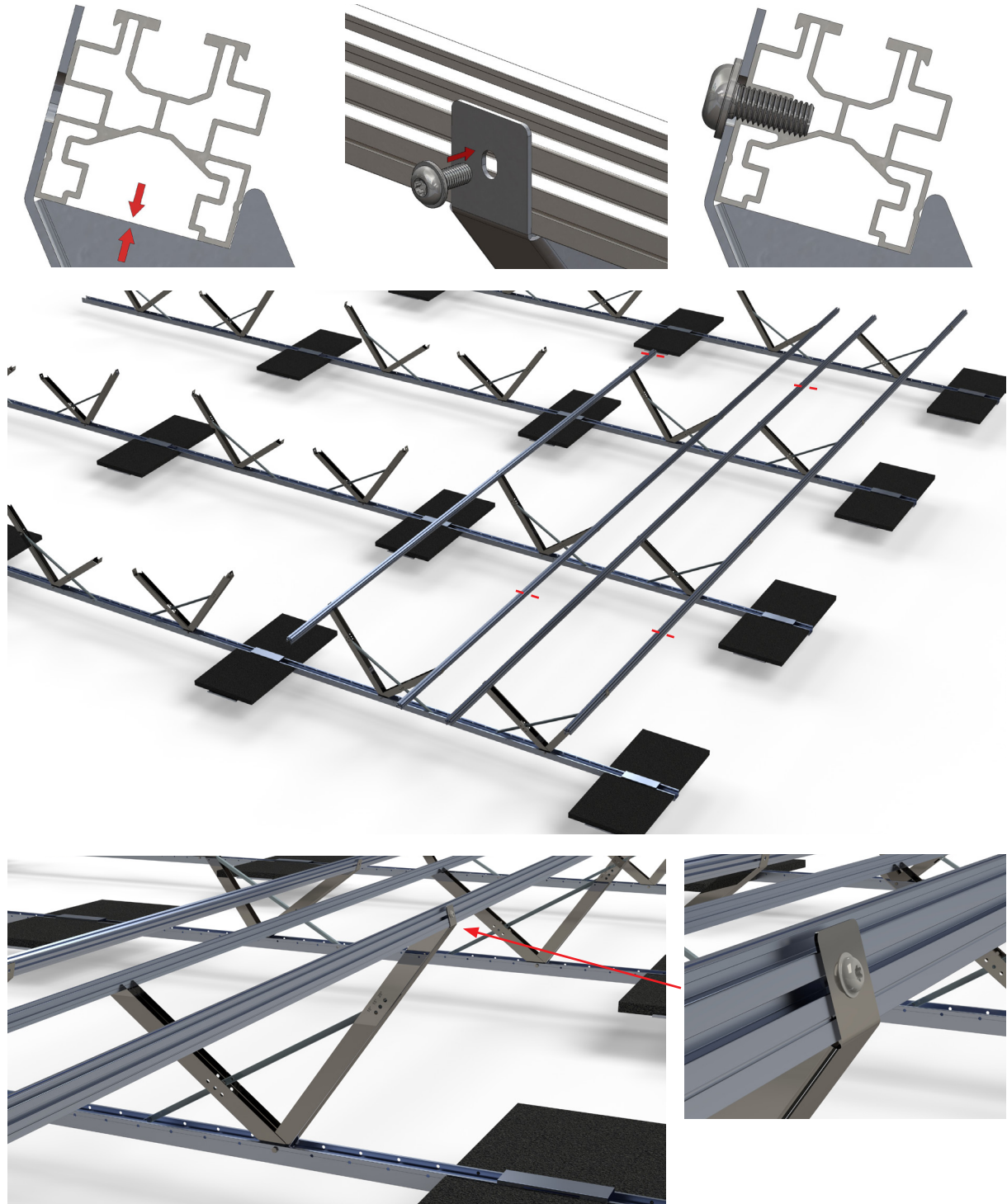

Mounting the profile rails

- The profile rail is calculated according to the following diagram.
- Calculation of overhang: Module width + module clamp + an additional module clamp at the end of the module row + 100 mm overhang at the start and end of the module row/rail length.
- If the remainder is shorter than 1000 mm, it is considered a waste. From 1000 mm, you must start with the remainder on the next rail.
- The installation is carried out in serpentine lines.

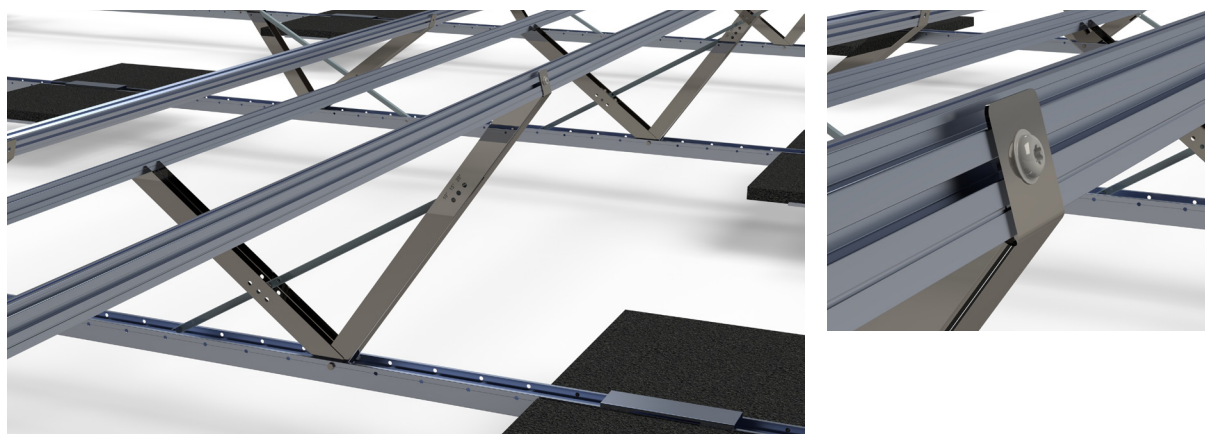
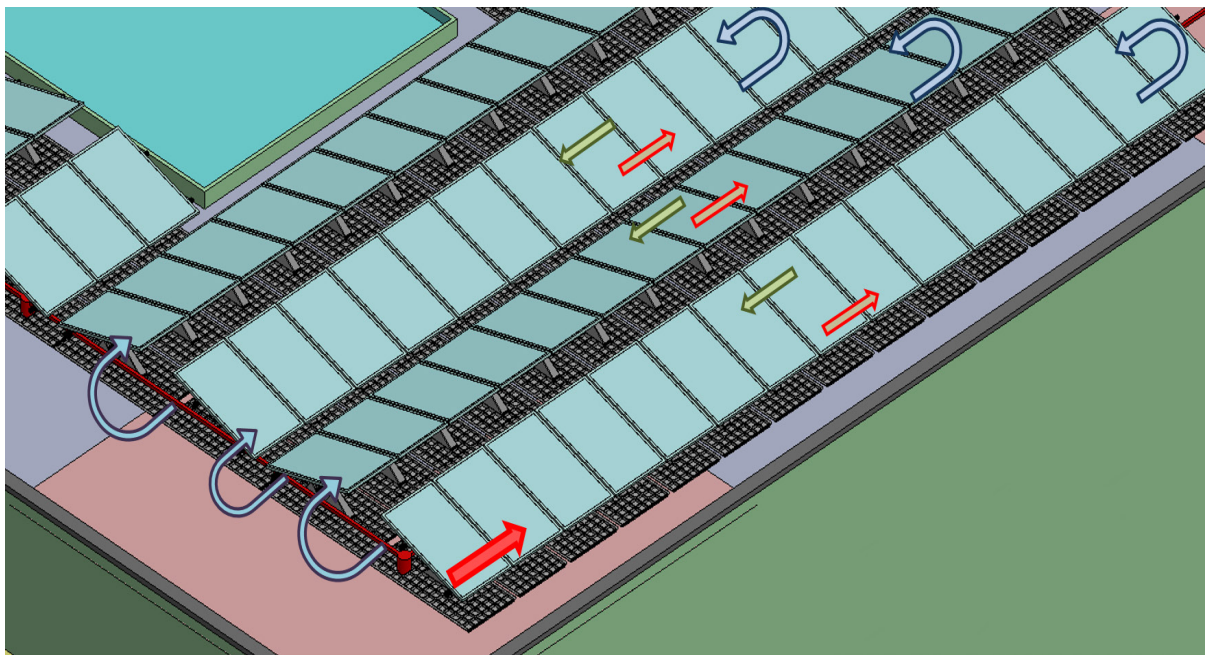

Work step 5

- The individual profile rails are screwed together with the L-shaped profile connector and 2 thread-forming screws M8 x 20 mm each.

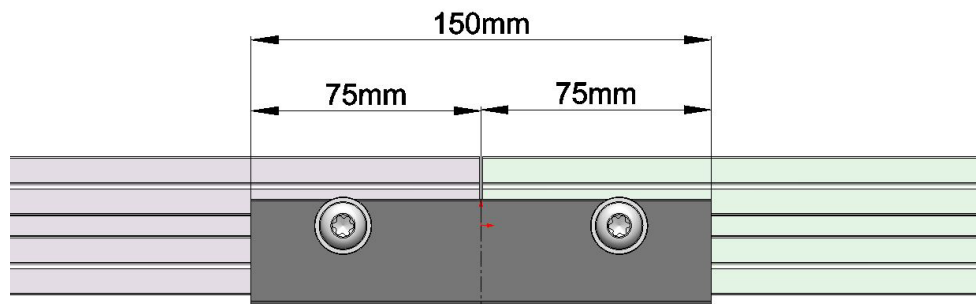
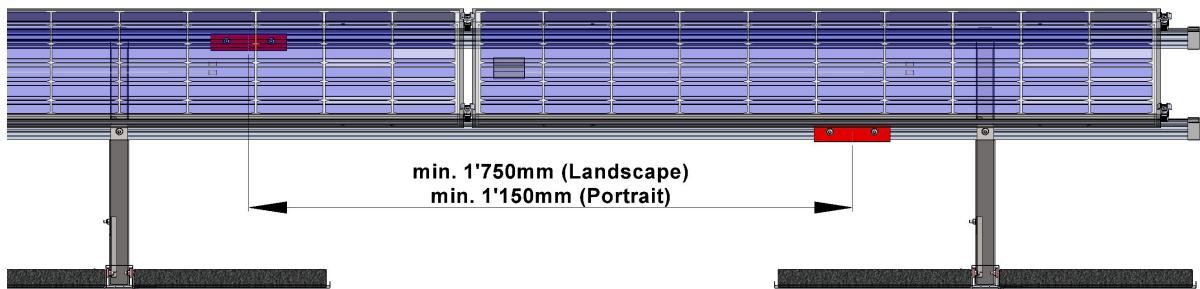

Mounting the modules

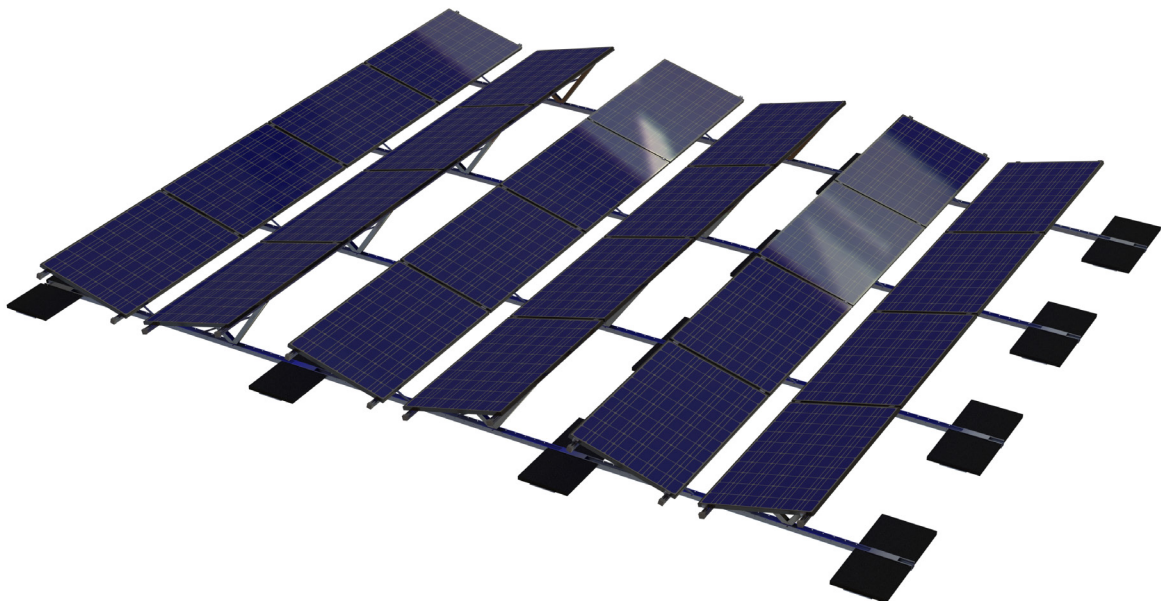

Work step 6

Mounting the modules

- Module assembly according to the manufacturer's specifications
- Adhere to clamping ranges
- Max. observe tightening torque of module terminal System components (page 7)

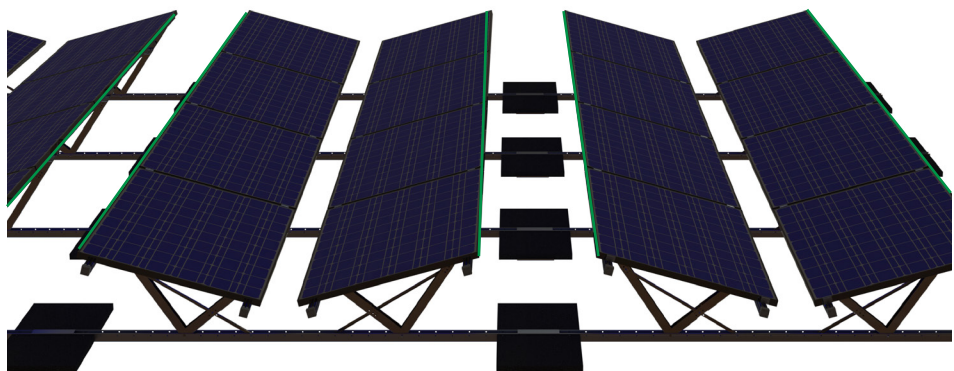
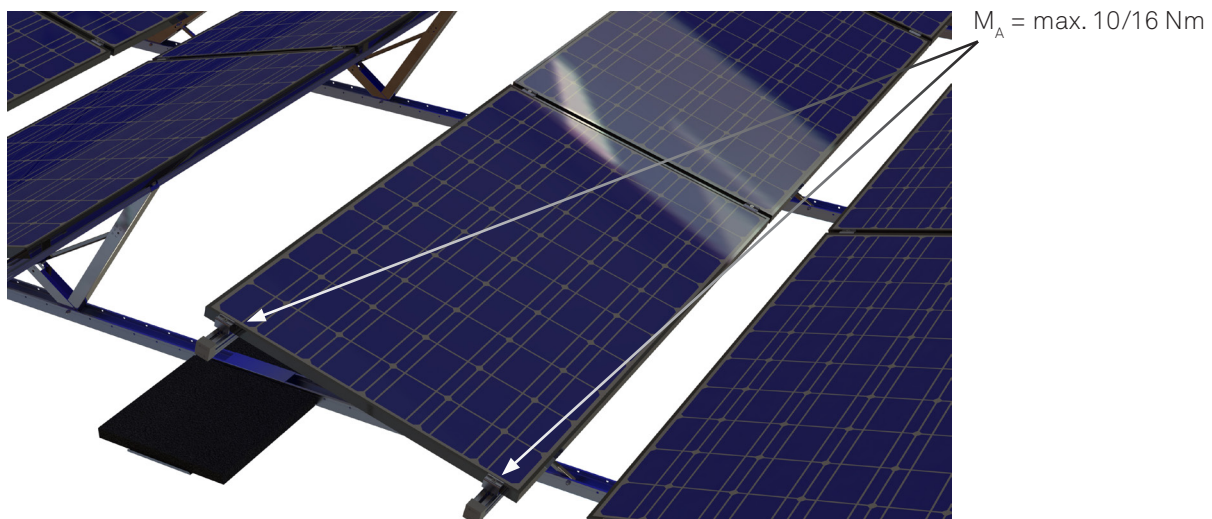
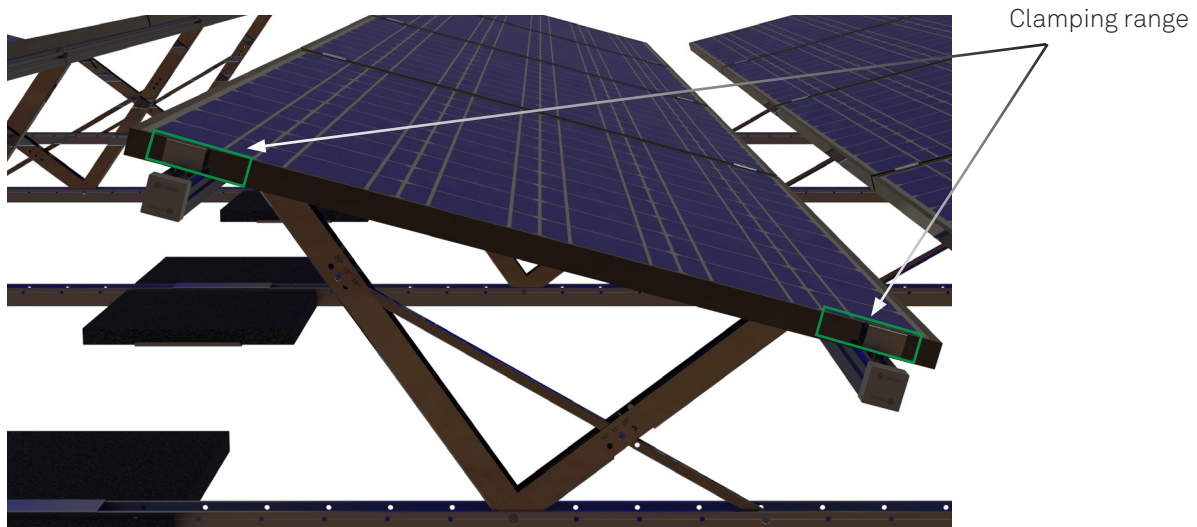

More hints

The following points must be observed urgently during assembly

- Only clamping systems approved by Contec AG may be used for mounting.
- The tightening torque (M_A) of the module clamps can be found in the system components. A suitable torque wrench or a cordless screwdriver with torque limiter must be used for this purpose. Lower tightening torques can lead to system failure.
- Do not drill, nail or weld on the module frames.
- Only use corrosion-free screws for mounting.
- The installation of the modules deviating from the planning by Contec AG, is only permitted after consultation and written approval of the manufacturer.
- In the case of an order, the system statics of Contec AG are taken over by the planning.
- The customer is responsible for the static release of the area to be covered.

Note Installation of the Contec.greenlight on top substructure module placement

- At the beginning and end of the row is allowed a maximum projection of the modules of 60 cm.
- Follow the manufacturer's instructions for module installation.

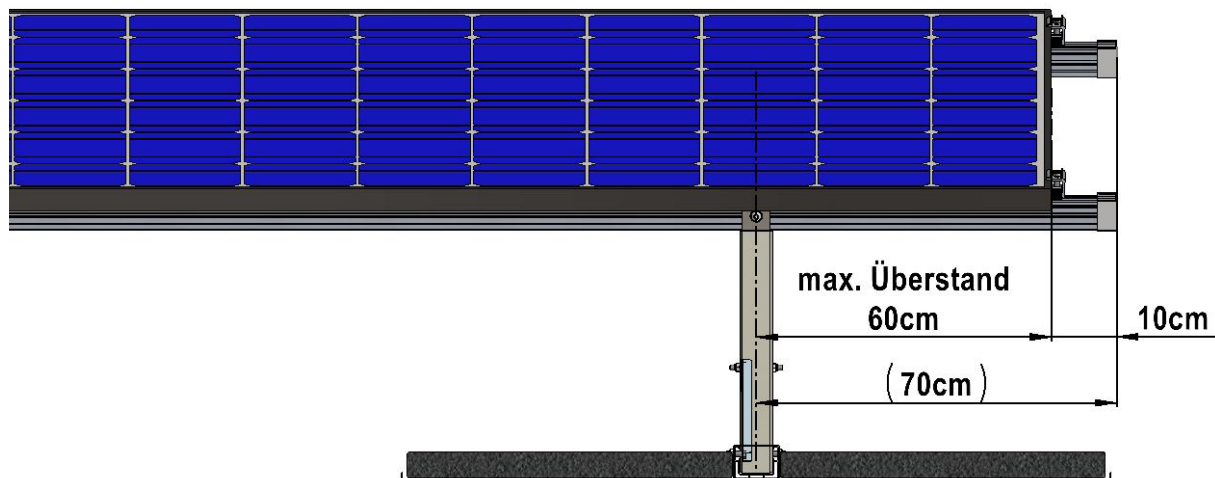

Lightning protection

- The conductivity of the mounting profile is 34-38 MS/m.

- Ballast: Ballast unit with garden slabs 50 cm x 50 cm x 4 cm (~21 kg).

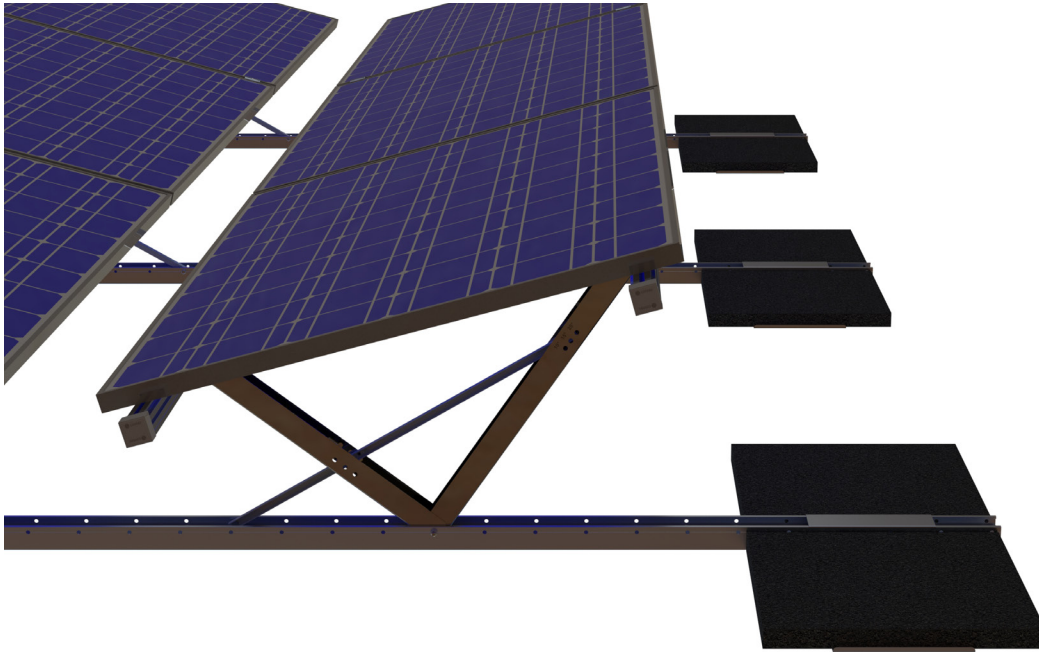

- The weight per unit area, the number of ballasting units including the number of garden slabs and the position/spacing are to be taken from the planning documents.
- Weight per ballasting unit 1x 2 pcs. = ~42 kg / 2x 2 pcs. = ~84 kg

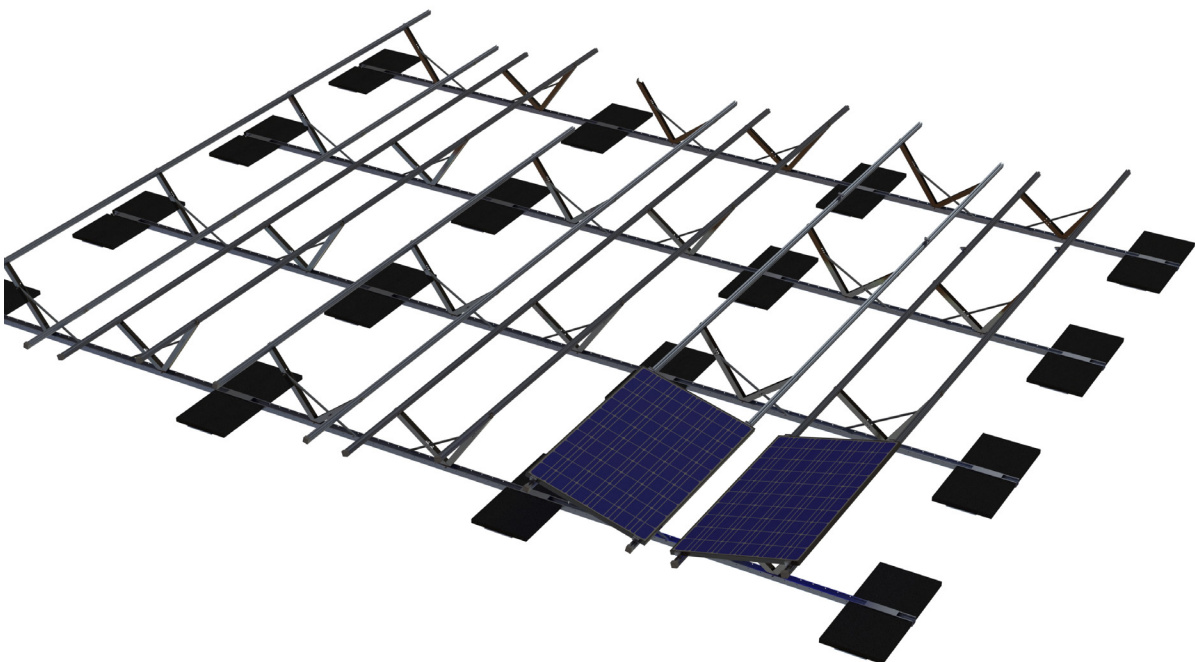

Contec.greenlight on top
The solution for the EnergyGreenRoof

